

HUFSCHMIED
ZERSpanungSSYSTEME

GERMAN INNOVATION – ONE CUT AHEAD

GRAPHIT-LINE
FRÄSWERKZEUGE FÜR DIE
ELEKTRODENFERTIGUNG



HIGH PERFORMANCE TOOLS
FRÄSEN UND BOHREN VON GRAPHIT

BY *Ralph Hufschmied*

Ausgabe 11/2022

Dieser Katalog ist urheberrechtlich geschützt. Nachdruck, auch auszugsweise, nur mit unserer ausdrücklichen schriftlichen Genehmigung erlaubt. Technische Änderungen unserer Produkte und Änderungen des Lieferprogramms im Zuge der Weiterentwicklung behalten wir uns vor.

Print version 11/2022

This catalogue is copyright protected. Reprints, also in parts, is possible with our permission only. Technical changes in our products within research and development are possible at any time.

Printed in Germany 2022

Mit dem Erscheinen dieses Kataloges werden alle vorherigen Exemplare, Preislisten und Preisvereinbarungen ungültig.

With the publication of this catalogue all previous copies, price lists and price agreements become invalid.

**EINEN SCHNITT VORAUSS.
HUFSCHMIED
ONE CUT AHEAD.**

**HUFSCHMIED
ZERSpanungssysteme GmbH**

Edisonstraße 11 d

D-86399 Bobingen

Tel.: +49 82 34-96 64 0

Fax: +49 82 34-96 64 99

info@hufschmied.net

HUFSCHMIED.NET 

WERKSTOFFOPTIMIERTES WERKZEUGPROGRAMM FÜR DIE PRÄZISE BEARBEITUNG VON GRAPHIT.



→ Ralph R. Hufschmied
Geschäftsführer

Hufschmied Zerspanungssysteme verfügt über 31 Jahre Erfahrung in der Entwicklung und Fertigung von prozessoptimierenden, materialbezogenen Werkzeugen. Unsere Stärke ist es, unsere Kunden in ihrem Bestreben zum bestmöglichen Fertigungsprozess zu beraten und die Prozesse mit Werkzeugen, wie Fräsern und Bohrern, von höchster Präzision partnerschaftlich zu optimieren. Dabei geht es nicht nur um die reine Werkzeuggeometrie, sondern wir beraten, entwickeln, programmieren, schulen und nehmen mit unseren Kunden die Werkzeuge in Betrieb und etablieren deutlich effizientere Prozesse sowohl auf den Maschinen als auch in der Denkweise unserer Kunden.

Hufschmied Zerspanungssysteme has over 31 years of experience in the development and production of process-optimizing, material-related tools. Our strength is to advise our customers in their efforts to achieve the best possible manufacturing process and to optimize processes in partnership with tools, such as milling cutters and drills, of the highest precision. This is not just about the pure tool geometry, but we advise, develop, program, train and commission the tools with our customers and establish significantly more efficient processes both on the machines and in the mindset of our customers.



HUFSCHMIED
jetzt live entdecken

Europas führender
Hersteller für
materialbezogene Werkzeuge.





Pic 1
Hufschmied versieht seine Werkzeuge mit Endmaßbeschriftung

Hufschmied provides tools with gauge block labeling

Wir haben deutlich weniger Verschleißerscheinungen am Graftor® und müssen dadurch die Werkzeuge weniger oft austauschen. Dadurch können wir die geforderten Maßhaltigkeiten und Toleranzen prozesssicherer einhalten.



With the Graftor®, there are significantly fewer signs of wear and therefore, the tools need to be replaced less often. This allows us to maintain the required dimensional accuracy and tolerances with greater process reliability.



Mario Heizmann, NC-Fertigung bei Aesculap, Tuttlingen, Deutschland.

Form Form	Werkzeug Tool	Seite Page
Graphit Line		
394GRM-R	MINI-GRAFTOR® KUGEL MINI-GRAFTOR® BALL	10
394GRM	MINI-GRAFTOR® TORUS MINI-GRAFTOR® TORUS	11
394GR-R	GRAFTOR® Schrupp-Schlicht-Kugelfräser GRAFTOR® roughing-finishing ball end mill	12
394GR	GRAFTOR® Schrupp-Schlicht-Torusfräser GRAFTOR® roughing-finishing toric end mill	13
394GRSK-R	GRAFTOR® RADIUSFRÄSER Z2 x 2 GRAFTOR® RADIUS END MILL 2F x 2	14
107GRR	SCHRUPP-KUGELFRÄSER ROUGHING BALL END MILL	19
107GR	SCHRUPP-FRÄSER ROUGHING END MILL	20
63CWIR	PIRANHA-KUGELFRÄSER Z3 PIRANHA-BALL END MILL 3F	21
63CWI	PIRANHA-FRÄSER Z3 PIRANHA END MILL 3F	22 - 23
HM915	MINI-KUGELFRÄSER Z2 MINI-BALL END MILL 2F	24 - 25
HM905	MINI-TORUSFRÄSER Z2 MINI-TORIC END MILL 2F	26 - 27
97DC	KUGELFRÄSER Z2 BALL END MILL 2F	28 - 29
93DC	SCHAFTFRÄSER Z2 END MILL 2F	30 - 31
97DCSK	KUGELFRÄSER Z2 - KONISCH BALL END MILL 2F - CONICAL	32
93DCSK	TORUSFRÄSER Z2 TORIC END MILL 2F	33
95DC	KUGELFRÄSER Z4 BALL END MILL 4F	34
91DC	SCHAFTFRÄSER Z4 END MILL 4F	35
P100RG	PKD-KUGELFRÄSER Z2 PCD-BALL END MILL 2F	36
P100G	PKD-TORUSFRÄSER Z2 PCD-TORIC END MILL 2F	37
110GF	GEWINDEFÄSER THREAD MILL	38
KD201	SPIRALBOHRER TAP DRILL	39
93DCECO	TORUSFRÄSER Z2 TORIC-END MILL 2F	40 - 41
97DCECO	KUGELFRÄSER Z2 BALL END MILL 2F	42
HM915ECO	MINI-KUGELFRÄSER Z2 MINI-BALL END MILL 2F	44
HM905ECO	MINI-TORUSFRÄSER Z2 MINI-TORIC-END MILL 2F	45

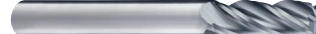



GRAPHIT-LINE

➔ Zielsetzung

Objective

Werkstoffoptimiertes Werkzeugprogramm für die präzise Bearbeitung von Graphit.

Material optimized tool program for precise machining of graphite.

➔ Vorteile

Advantages

Mit den Werkzeugen der Graphit-Line werden höchste Formgenauigkeit und eine Reduzierung der Bearbeitungskosten bei der Fertigung von Elektroden aus Graphit erreicht. Sie zeichnen sich durch höchste Rundlaufgenauigkeit und extrem hohe Standzeiten aus und verkürzen zudem die Bearbeitungszeiten erheblich. HSC- und HPC-Bearbeitung möglich.

The tools of the Graphite-Line ensure highest accuracy of shape and reduction of processing costs for production of graphite electrodes. Above that they distinguish themselves with highest runout precision coupled with extremely high durability while also reducing machining duration. HSC and HPC machining possible.

➔ Ausführungen

Designs

Das Werkzeugprogramm ist vielfältig und wird ständig erweitert. Durch kontinuierliche Forschung und Entwicklung bleibt es stets auf dem neuesten Stand der Technik.

Our range of tools is diverse and is constantly being expanded. Through continual research and development, it always remains at the cutting edge of technology.



Wir konnten bei gleichbleibender Oberflächenqualität eine deutliche Laufzeitreduzierung erreichen.



Benjamin Nieth, Production Controller bei ElringKlinger AG, Lenningen, Deutschland.

DIP®-BESCHICHTUNG

DIP®-COATING

- ➔ **DIP®** ist eine mehrlagige CVD-Diamantschicht bestehend aus einer nanokristallinen Diamantschicht und einer sehr glatten Schmierstoff-Deckschicht, ebenfalls auf Kohlenstoffbasis.

DIP® ist 100% perfekter Diamant, gemessen in echten Karat (ct). Diamant, das härteste in der Natur vorkommende Material, ist extrem widerstandsfähig gegen mechanische Abrasion. Die Nanostruktur der Kristalle gewährleistet geringste Reibung und beste Schichthaftung bei minimaler Schneidkantenverrundung.

Die Kohlenstoffdeckschicht sorgt nicht nur für Schmierung, sondern verhindert zudem das Ausbrechen von Diamantkristallen und damit das frühzeitige Versagen des Schichtkomplexes.

DIP® Kundennutzen - bessere Standzeiten, geringere Rüstzeiten, weniger Stillstand, beste Werkstückoberfläche und mehr Produktivität.

- ➔ *DIP® is a multi-layer CVD diamond coating from a nano-crystalline diamond layer and a very smooth lubricant surface layer, likewise on carbon basis. DIP® is 100% perfect diamond, counted in carat (ct).*

Diamond, the hardest material occurring in nature, is extremely resistant against mechanical abrasion. The nano-structure of the crystals ensures least friction and best layer adhesion plus minimum cutting edge roundness.

The carbon surface layer provides not only lubrication, but prevents breaking out diamond crystals and thus the early failure of the layer complex.

DIP® customer value - longer tool live, shorter preparation times, less machine stop, best work piece surface and higher productivity.



Wir forschen und entwickeln kontinuierlich, damit unsere Kunden auf Dauer zu den innovativsten und wettbewerbsfähigsten in ihrer Branche gehören. Der Grafortor® ist ein gutes Beispiel für dieses Engagement.



Ralph R. Hufschmied, Geschäftsführer bei HUFSCHMIED Zerspanungssysteme GmbH, Bobingen, Deutschland.



↓ Pic 3
Detailaufnahme eines
Graftor®-Werkzeugs.

Close-up of a Graftor®
tool.



→ Durchmesserbereich:
0,5 bis 2,0 mm

diameter range:
0,5 to 2,0 mm



MINI-GRAFTOR® KUGELFRÄSER (KOPFRADIUS R = 0,5 X D1)						
BESTELL-NUMMER ORDER NUMBER	D1 mm	D2 h6 mm	L2 mm	L1 mm	L3 mm	
0,5	394GRMA005R-025-DIP	0,5	4	0,7	50	2,5
	394GRMA005R-050-DIP	0,5	4	0,7	50	5
	394GRMA005R-075-DIP	0,5	4	0,7	50	7,5
	394GRMA005R-100-DIP	0,5	4	0,7	50	10
	394GRMAA005R-025-DIP	0,5	6	0,7	50	2,5
	394GRMAA005R-050-DIP	0,5	6	0,7	50	5
	394GRMAA005R-075-DIP	0,5	6	0,7	50	7,5
	394GRMAA005R-100-DIP	0,5	6	0,7	50	10
0,6	394GRMA006R-030-DIP	0,6	4	0,8	50	3
	394GRMA006R-060-DIP	0,6	4	0,8	50	6
	394GRMA006R-090-DIP	0,6	4	0,8	50	9
	394GRMA006R-120-DIP	0,6	4	0,8	50	12
	394GRMAA006R-030-DIP	0,6	6	0,8	50	3
	394GRMAA006R-060-DIP	0,6	6	0,8	50	6
	394GRMAA006R-090-DIP	0,6	6	0,8	50	9
	394GRMAA006R-120-DIP	0,6	6	0,8	50	12
0,8	394GRMA008R-040-DIP	0,8	4	1,0	60	4
	394GRMA008R-080-DIP	0,8	4	1,0	60	8
	394GRMA008R-120-DIP	0,8	4	1,0	60	12
	394GRMA008R-160-DIP	0,8	4	1,0	60	16
	394GRMAA008R-040-DIP	0,8	6	1,0	60	4
	394GRMAA008R-080-DIP	0,8	6	1,0	60	8
	394GRMAA008R-120-DIP	0,8	6	1,0	60	12
	394GRMAA008R-160-DIP	0,8	6	1,0	60	16
1,0	394GRMA010R-050-DIP	1,0	4	1,2	60	5
	394GRMA010R-100-DIP	1,0	4	1,2	60	10
	394GRMA010R-150-DIP	1,0	4	1,2	60	15
	394GRMA010R-200-DIP	1,0	4	1,2	60	20
	394GRMAA010R-050-DIP	1,0	6	1,2	60	5
	394GRMAA010R-100-DIP	1,0	6	1,2	60	10
	394GRMAA010R-150-DIP	1,0	6	1,2	60	15
	394GRMAA010R-200-DIP	1,0	6	1,2	60	20
1,5	394GRMA015R-075-DIP	1,5	4	1,7	60	7,5
	394GRMA015R-150-DIP	1,5	4	1,7	60	15
	394GRMA015R-250-DIP	1,5	4	1,7	60	25
	394GRMAA015R-075-DIP	1,5	6	1,7	60	7,5
	394GRMAA015R-150-DIP	1,5	6	1,7	60	15
	394GRMAA015R-250-DIP	1,5	6	1,7	60	25
2,0	394GRMA020R-100-DIP	2,0	4	2,2	60	10
	394GRMA020R-200-DIP	2,0	4	2,2	60	20
	394GRMA020R-300-DIP	2,0	4	2,2	75	30
	394GRMA020R-400-DIP	2,0	4	2,2	75	40
	394GRMAA020R-100-DIP	2,0	6	2,2	60	10
	394GRMAA020R-200-DIP	2,0	6	2,2	60	20
	394GRMAA020R-300-DIP	2,0	6	2,2	75	30
	394GRMAA020R-400-DIP	2,0	6	2,2	75	40

MINI-GRAFTOR® TORUSFRÄSER

BESTELL-NUMMER ORDER NUMBER	D1 mm	D2 h6 mm	L2 mm	L1 mm	L3 mm	ER mm
0,5 394GRMA005-010-025-DIP	0,5	4	0,7	50	2,5	0,1
394GRMA005-010-050-DIP	0,5	4	0,7	50	5	0,1
394GRMA005-010-075-DIP	0,5	4	0,7	50	7,5	0,1
394GRMA005-010-100-DIP	0,5	4	0,7	50	10	0,1
394GRMAA005-010-025-DIP	0,5	6	0,7	50	2,5	0,1
394GRMAA005-010-050-DIP	0,5	6	0,7	50	5	0,1
394GRMAA005-010-075-DIP	0,5	6	0,7	50	7,5	0,1
394GRMAA005-010-100-DIP	0,5	6	0,7	50	10	0,1
0,6 394GRMA006-010-030-DIP	0,6	4	0,8	50	3	0,1
394GRMA006-010-060-DIP	0,6	4	0,8	50	6	0,1
394GRMA006-010-090-DIP	0,6	4	0,8	50	9	0,1
394GRMA006-010-120-DIP	0,6	4	0,8	50	12	0,1
394GRMAA006-010-030-DIP	0,6	6	0,8	50	3	0,1
394GRMAA006-010-060-DIP	0,6	6	0,8	50	6	0,1
394GRMAA006-010-090-DIP	0,6	6	0,8	50	9	0,1
394GRMAA006-010-120-DIP	0,6	6	0,8	50	12	0,1
0,8 394GRMA008-010-040-DIP	0,8	4	1,0	60	4	0,1
394GRMA008-010-080-DIP	0,8	4	1,0	60	8	0,1
394GRMA008-010-120-DIP	0,8	4	1,0	60	12	0,1
394GRMA008-010-160-DIP	0,8	4	1,0	60	16	0,1
394GRMAA008-010-040-DIP	0,8	6	1,0	60	4	0,1
394GRMAA008-010-080-DIP	0,8	6	1,0	60	8	0,1
394GRMAA008-010-120-DIP	0,8	6	1,0	60	12	0,1
394GRMAA008-010-160-DIP	0,8	6	1,0	60	16	0,1
1,0 394GRMA010-020-050-DIP	1,0	4	1,2	60	5	0,2
394GRMA010-020-100-DIP	1,0	4	1,2	60	10	0,2
394GRMA010-020-150-DIP	1,0	4	1,2	60	15	0,2
394GRMA010-020-200-DIP	1,0	4	1,2	60	20	0,2
394GRMAA010-020-050-DIP	1,0	6	1,2	60	5	0,2
394GRMAA010-020-100-DIP	1,0	6	1,2	60	10	0,2
394GRMAA010-020-150-DIP	1,0	6	1,2	60	15	0,2
394GRMAA010-020-200-DIP	1,0	6	1,2	60	20	0,2
1,5 394GRMA015-020-075-DIP	1,5	4	1,7	60	7,5	0,2
394GRMA015-020-150-DIP	1,5	4	1,7	60	15	0,2
394GRMA015-020-250-DIP	1,5	4	1,7	60	25	0,2
394GRMAA015-020-075-DIP	1,5	6	1,7	60	7,5	0,2
394GRMAA015-020-150-DIP	1,5	6	1,7	60	15	0,2
394GRMAA015-020-250-DIP	1,5	6	1,7	60	25	0,2
2,0 394GRMA020-020-100-DIP	2,0	4	2,2	60	10	0,2
394GRMA020-020-200-DIP	2,0	4	2,2	60	20	0,2
394GRMA020-020-300-DIP	2,0	4	2,2	75	30	0,2
394GRMA020-020-400-DIP	2,0	4	2,2	75	40	0,2
394GRMAA020-020-100-DIP	2,0	6	2,2	60	10	0,2
394GRMAA020-020-200-DIP	2,0	6	2,2	60	20	0,2
394GRMAA020-020-300-DIP	2,0	6	2,2	75	30	0,2
394GRMAA020-020-400-DIP	2,0	6	2,2	75	40	0,2



GRAPHIT LINE

➔ Durchmesserbereich:
0,5 bis 2,0 mm

diameter range:
0,5 to 2,0 mm

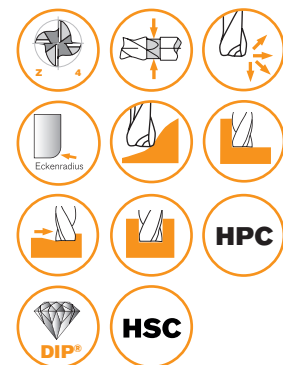

GRAPHIT LINE

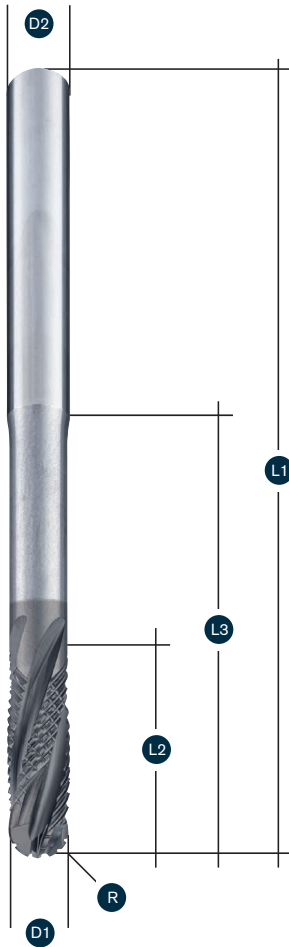

GRAFTOR® KUGELFRÄSER (KOPFRADIUS R = 0,5 X D1)

	BESTELL-NUMMER ORDER NUMBER	D1 mm	D2 h6 mm	L2 mm	L1 mm	L3 mm
1,0	394GR01R-DIP	1	6	3	60	10
	394GRF01R-DIP	1	6	3	60	15
1,5	394GR015R-DIP	1,5	6	5	60	20
2,0	394GR02R-DIP	2	6	8	60	20
	394GRFK02R-DIP	2	6	6	75	30
	394GRFL02R-DIP	2	6	4	100	40
3,0	394GRK03R-DIP	3	6	10	60	15
	394GR03R-DIP	3	6	10	60	30
	394GRFK03R-DIP	3	6	10	75	40
	394GRFL03-DIP	3	6	10	100	50
4,0	394GRK04R-DIP	4	6	12	60	20
	394GR04R-DIP	4	6	12	60	30
	394GRXL04R-DIP	4	6	12	75	40
	394GRFL04R-DIP	4	6	12	100	50
5,0	394GR05R-DIP	5	6	15	60	30
	394GRXL05R-DIP	5	6	15	75	40
	394GRFL05R-DIP	5	6	15	100	50
6,0	394GR06R-DIP	6	6	16	60	30
	394GRL06R-DIP	6	6	16	75	40
	394GRXL06R-DIP	6	6	16	100	50
8,0	394GR08R-DIP	8	8	18	63	30
	394GRL08R-DIP	8	8	18	75	40
	394GRXL08R-DIP	8	8	18	100	50
10,0	394GR10R-DIP	10	10	22	72	35
	394GRL10R-DIP	10	10	22	100	40
	394GRXL10R-DIP	10	10	22	120	60
12,0	394GR12R-DIP	12	12	26	83	40
	394GRL12R-DIP	12	12	26	100	50
	394GRXL12R-DIP	12	12	26	150	100

➔ Durchmesserbereich:
1,0 bis 12,0 mm

diameter range:
1,0 to 12,0 mm



GRAFTOR [®] TORUSFRÄSER							
BESTELL-NUMMER ORDER NUMBER	D1 mm	D2 h6 mm	L2 mm	L1 mm	L3 mm	ER	
1,0	394GR01-020-DIP	1	6	3	60	15	0,2
1,5	394GR015-020-DIP	1,5	6	5	60	20	0,2
2,0	394GR02-020-DIP	2	6	8	60	20	0,2
	394GRFL02-020-DIP	2	6	4	100	40	0,2
3,0	394GRK03-020-DIP	3	6	10	60	15	0,2
	394GR03-020-DIP	3	6	10	60	30	0,2
	394GRFK03-020-DIP	3	6	10	75	40	0,2
	394GRFL03-020-DIP	3	6	10	100	50	0,2
4,0	394GRK04-050-DIP	4	6	12	60	20	0,5
	394GR04-050-DIP	4	6	12	60	30	0,5
	394GRXL04-050-DIP	4	6	12	75	40	0,5
	394GRFL04-050-DIP	4	6	12	100	50	0,5
5,0	394GR05-050-DIP	5	6	15	60	30	0,5
	394GRXL05-050-DIP	5	6	15	75	40	0,5
	394GRFL05-050-DIP	5	6	15	100	50	0,5
6,0	394GR06-050-DIP	6	6	16	60	30	0,5
	394GR06-100-DIP	6	6	16	60	30	1
	394GRL06-050-DIP	6	6	16	75	40	0,5
	394GRXL06-100-DIP	6	6	16	75	40	1
	394GRXL06-050-DIP	6	6	16	100	50	0,5
	394GRXL06-100-DIP	6	6	16	100	50	1
8,0	394GR08-050-DIP	8	8	18	63	30	0,5
	394GR08-100-DIP	8	8	18	63	30	1
	394GRL08-050-DIP	8	8	18	75	40	0,5
	394GRL08-100-DIP	8	8	18	75	40	1
	394GRXL08-050-DIP	8	8	18	100	50	0,5
	394GRXL08-100-DIP	8	8	18	100	50	1
10,0	394GR10-050-DIP	10	10	22	72	35	0,5
	394GR10-100-DIP	10	10	22	72	35	1
	394GRL10-050-DIP	10	10	22	100	40	0,5
	394GRL10-100-DIP	10	10	22	100	40	1
	394GRXL10-050-DIP	10	10	22	120	60	0,5
	394GRXL10-100-DIP	10	10	22	120	60	1
12,0	394GR12-050-DIP	12	12	26	83	40	0,5
	394GR12-100-DIP	12	12	26	83	40	1
	394GRL12-050-DIP	12	12	26	100	50	0,5
	394GRL12-100-DIP	12	12	26	100	50	1
	394GRXL12-050-DIP	12	12	26	150	100	0,5
	394GRXL12-100-DIP	12	12	26	150	100	1

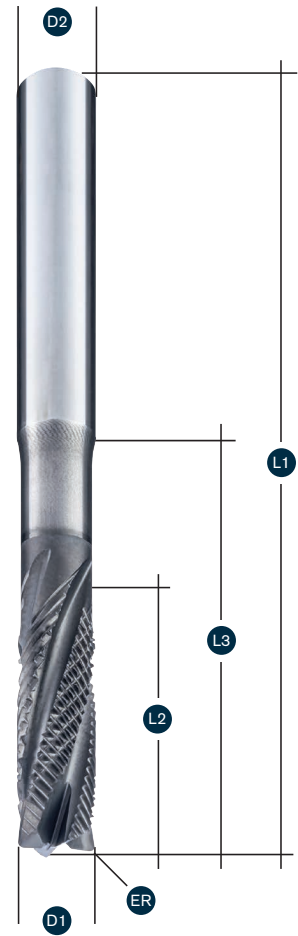

GRAPHIT LINE

➔ **Durchmesserbereich:**
1,0 bis 12,0 mm

diameter range:
1,0 to 12,0 mm



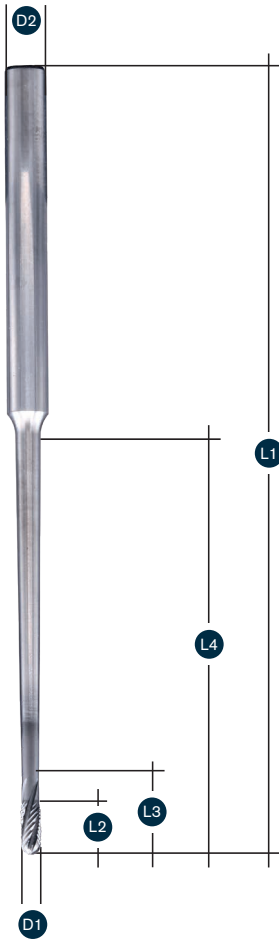

394GRSK-R

	BESTELL-NUMMER ORDER NUMBER	D1 mm	D2 h6 mm	L2 mm	L1 mm	L3 mm	L4 mm	A _{max} °
1,0	394GRSK010R-020-DIP	1	6	1	60	2	20	1
	394GRSK010R-030-DIP	1	6	1	60	2	30	1
	394GRSK010R-040-DIP	1	6	1	75	2	40	1
1,5	394GRSK015R-030-DIP	1,5	6	1,5	60	3	30	1
	394GRSK015R-045-DIP	1,5	6	1,5	75	3	45	1
	394GRSK015R-060-DIP	1,5	6	1,5	100	3	60	1
2,0	394GRSK020R-040-DIP	2	6	2	75	4	40	1
	394GRSK020R-060-DIP	2	6	2	100	4	60	1
	394GRSK020R-080-DIP	2	6	2	125	4	80	1
3,0	394GRSK030R-060-DIP	3	6	3	100	5	60	1
	394GRSK030R-080-DIP	3	6	3	100	5	80	1
	394GRSK030R-090-DIP	3	8	3	125	5	90	1
4,0	394GRSK040R-060-DIP	4	6	4	100	6	60	1
	394GRSK040R-080-DIP	4	8	4	125	6	80	1
	394GRSK040R-100-DIP	4	8	4	150	6	100	1
6,0	394GRSK060R-060-DIP	6	8	6	100	8	60	1
	394GRSK060R-080-DIP	6	10	6	125	8	80	1
	394GRSK060R-100-DIP	6	10	6	150	8	100	1
8,0	394GRSK080R-080-DIP	8	10	8	125	10	80	1
	394GRSK080R-100-DIP	8	12	8	150	10	100	1
10,0	394GRSK100R-100-DIP	10	12	10	150	12	100	1

→ Durchmesserbereich:
1,0 bis 10,0 mm

diameter range:
1,0 to 10,0 mm



24H ZUVERLÄSSIG

Der Graftor® macht präzise, was er soll. Auch wenn Sie schlafen.

In der Praxis getestet und für überlegen befunden: Der Graftor® bewährt sich dort, wo höchste Anforderungen an Qualität und Zuverlässigkeit gestellt werden. Zum Beispiel bei Vetimec Soc. Coop. in Bologna. Das Unternehmen beliefert die internationale Automobilindustrie und Gießereien unter anderem mit anspruchsvollen Spritzgussformen. Senkerodieren ist das wichtigste Verfahren bei der Herstellung von Formen für den Spritzguss. Die Produktivität bei der Herstellung der Formen hängt entscheidend vom Prozess der Elektrodenfertigung ab. Hier können die revolutionären Spezialwerkzeuge von Hufschmied ihre Überlegenheit ausspielen: Mit dem Graftor® bearbeitet Vetimec Graphit heute um 30 % schneller und zugleich 20 % wirtschaftlicher als mit den bislang verfügbaren konventionellen Werkzeugen.



Scannen Sie den QR-Code und lesen Sie den VETIMEC-Artikel.

Der Graftor® ist das einzige Werkzeug, das wir prozesssicher im 24/7-Betrieb einsetzen können. Dies ist maßgeblich der hohen Standzeit geschuldet.



Massimo Lolli, Vice President bei VETIMEC Soc. Coop.,
Bologna, Italien.



CHAPTER 02
Gemacht für die
mannlose Bearbeitung

Bewährt im 24/7-Betrieb.
Absolut prozesssicher

DIE NEUE BENCHMARK

Der Graftor® im Vergleich mit konventionellen Werkzeugen. Nicht ganz fair, aber ganz eindeutig.

Schneidengeometrie, Standzeit, Präzision – die innovativen Graftor®-Werkzeuge sind konventionellen Werkzeugen in jeder Hinsicht und bis um das Dreifache überlegen. Selbst im Vergleich mit den material- und prozessoptimierten Werkzeugen der Hufschmied Graphit-Line ergibt sich ein deutlicher Zuwachs an Geschwindigkeit und Präzision. Alle relevanten Parameter zeigen signifikante Vorteile für die Graftor®-Technologie. Die meisten betrachten nur die absoluten Kosten, wie z. B. die Werkzeugkosten (Preise). Es ist jedoch entscheidend, diese Kosten in Relation zu setzen, um die tatsächlichen Produktionskosten bzw. die „Costs per part“ zu ermitteln.

COSTS PER PART

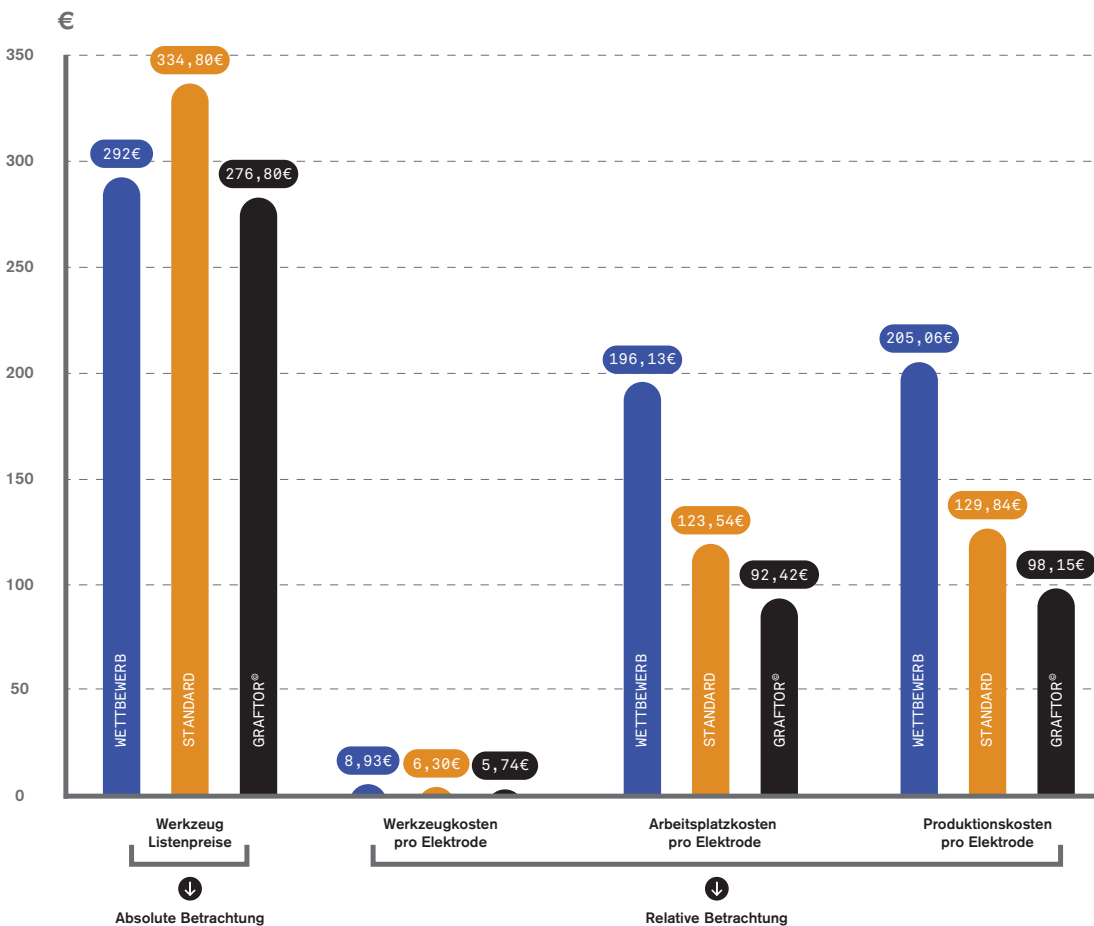

MASSHALTIGKEIT

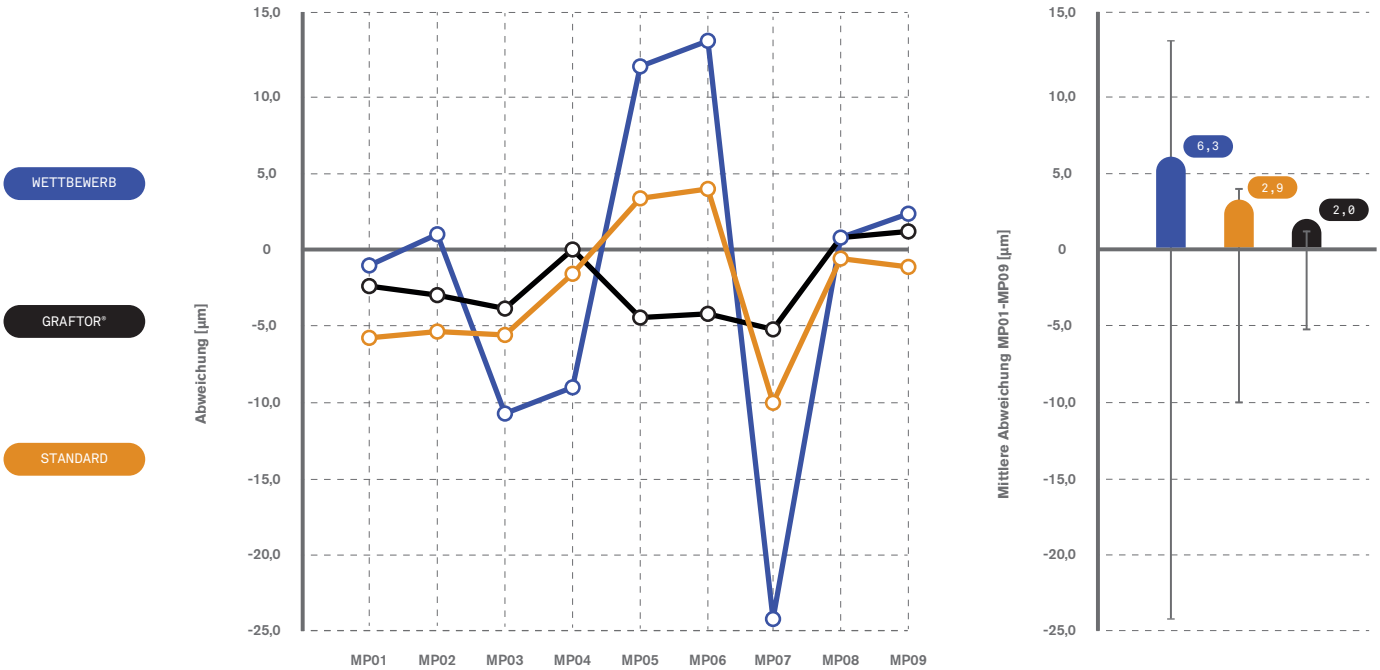

Auch in Sachen Maßhaltigkeit und Oberfläche überzeugt die Graftor®-Serie. Die Messungen wurden an der in dieser Broschüre beschriebenen „HZS-Elektrode“ durchgeführt. Sowohl die Streubreite als auch die mittlere Abweichung sind mit der Graftor®-Strategie am geringsten. Die besten Oberflächengüten werden ebenfalls mit Hufschmied-Werkzeugen erzielt. Mit dem erzielten Ra-Wert von 0,603 µm ist faktisch VDI 16, durch optimale Prozessbedingungen beim Erodieren sogar VDI 14 (entspricht Ra=0,5 µm), möglich. Das verwendete Graphit ist eine Ultrafeinstkornsorte mit der Bezeichnung EDM-1®. Die durchschnittliche Partikelgröße beträgt < 5µm.

OBERFLÄCHENGÜTE

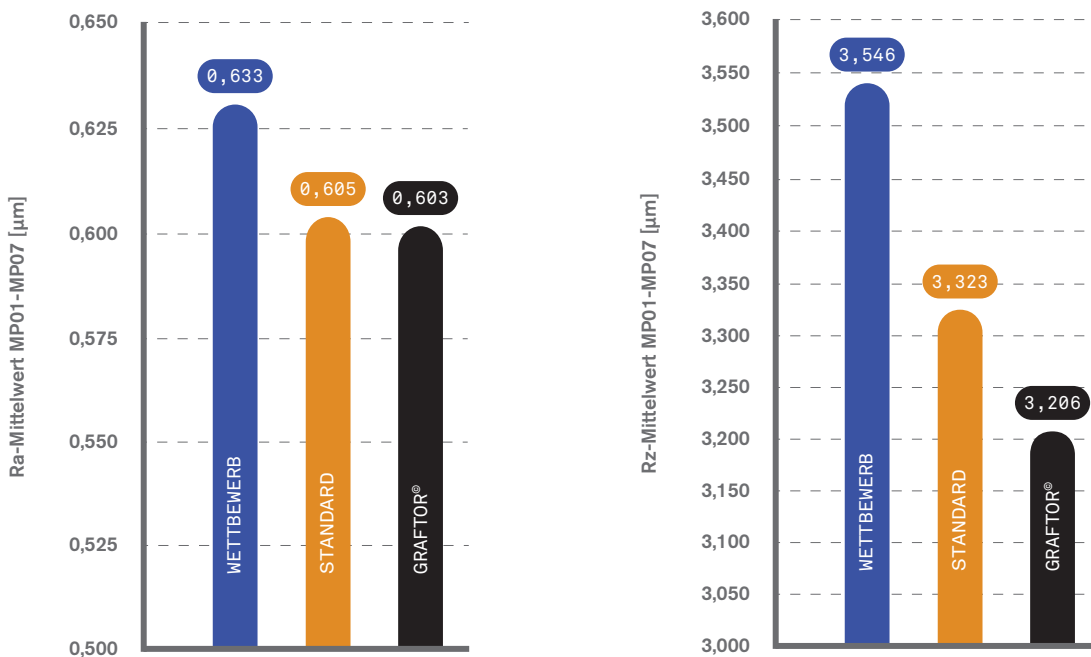

Die eindeutige Sprache der Zahlen



CHAPTER 05
Ein Vergleich mit
konventionellen Werkzeugen



Pic 9

Elektrodenvermessung

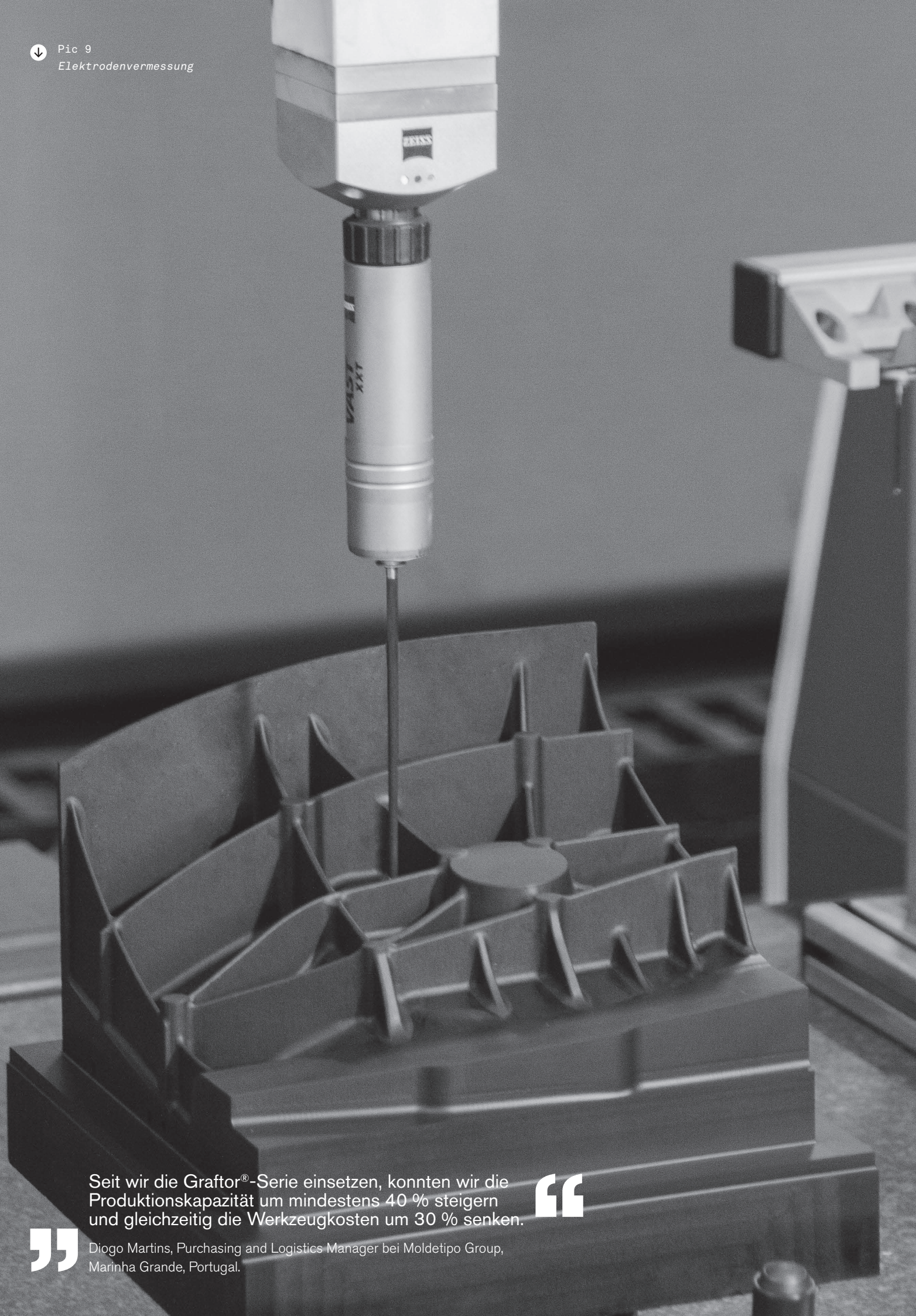

Seit wir die Graftor®-Serie einsetzen, konnten wir die Produktionskapazität um mindestens 40 % steigern und gleichzeitig die Werkzeugkosten um 30 % senken.



Diogo Martins, Purchasing and Logistics Manager bei Moldetipo Group, Marinha Grande, Portugal.

SCHRUPP-KUGELFRÄSER

Kopfradius R = 0,5 x D1

107GRR

ROUGHING BALL END MILL

ball radius R = 0,5 x D1

107GRR SCHRUPP-KUGELFRÄSER (KOPFRADIUS R = 0,5 X D1)

	BESTELL-NUMMER ORDER NUMBER	D1 mm	D2 h6 mm	L2 mm	L1 mm	L3 mm
3,0	107GR03R-WD	3	3	10	50	
	107GR03FR-WD	3	3	5	50	20
4,0	107GR04R-WD	4	4	12	50	
	107GR04FR-WD	4	4	5	50	20
5,0	107GR05R-WD	5	5	15	62	
	107GR05LR-WD	5	6	8	100	50
6,0	107GR06R-WD	6	6	18	60	
	107GR06LR-WD	6	6	10	100	50
	107GR06FR-WD	6	6	6	100	70
8,0	107GR08R-WD	8	8	20	63	
	107GR08LR-WD	8	8	12	100	60
	107GR08FR-WD	8	8	8	125	70
10,0	107GR10R-WD	10	10	25	72	
	107GR10LR-WD	10	10	15	100	60
	107GR10FR-WD	10	10	10	125	80
12,0	107GR12R-WD	12	12	30	83	
	107GR12XLR-WD	12	12	30	150	100
	107GR12FR-WD	12	12	12	125	80
16,0	107GR16KR-WD	16	16	20	100	
	107GR16R-WD	16	16	35	150	100

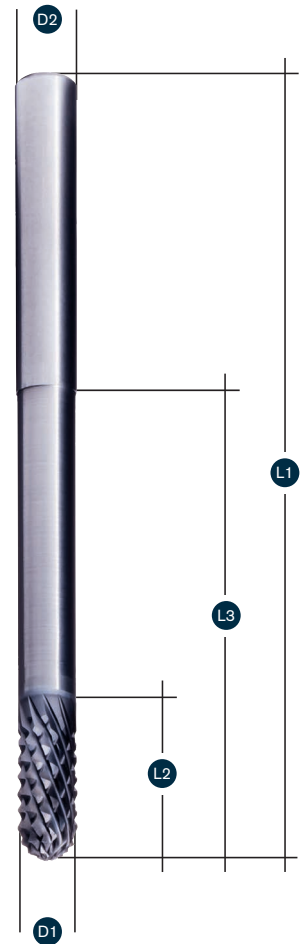

GRAPHIT / **LINE**

→ Durchmesserbereich:
3,0 bis 16,0 mm

diameter range:
3,0 to 16,0 mm

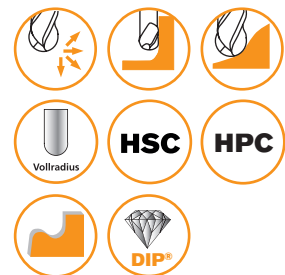

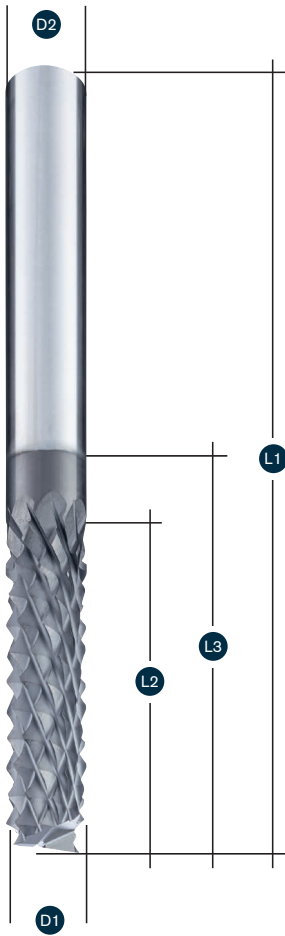

107GR SCHRUPPFÄSER						
BESTELL-NUMMER ORDER NUMBER	D1 mm	D2 h6 mm	L2 mm	L1 mm	L3 mm	
2,0 107GR02-WD	2	3	4	50	18	
3,0 107GR03-WD	3	3	10	50		
107GR03F-WD	3	3	5	50	20	
4,0 107GR04-WD	4	4	12	50		
107GR04F-WD	4	4	5	50	20	
5,0 107GR05-WD	5	5	15	62		
107GR05L-WD	5	6	8	100	50	
6,0 107GR06-WD	6	6	18	60		
107GR06L-WD	6	6	10	100	60	
107GR06F-WD	6	6	6	100	70	
8,0 107GR08-WD	8	8	20	63		
107GR08L-WD	8	8	12	100	60	
107GR08F-WD	8	8	8	125	70	
10,0 107GR10-WD	10	10	25	72		
107GR10L-WD	10	10	15	100	60	
107GR10F-WD	10	10	10	125	80	
12,0 107GR12-WD	12	12	30	83		
107GR12XL-WD	12	12	30	150	100	
107GR12F-WD	12	12	12	125	80	
16,0 107GR16K-WD	16	16	20	100		
107GR16-WD	16	16	35	150	100	

→ Durchmesserbereich:
2,0 bis 16,0 mm

diameter range:
2,0 to 16,0 mm



PIRANHA-BALL END MILL 3F

ball radius R = 0,5 x D1

63CWIR PIRANHA-KUGELFRÄSER

	BESTELL-NUMMER ORDER NUMBER	D1 mm	D2 h6 mm	L2 mm	L1 mm	L3 mm
1	63CWIR01-DIP	1	3	5	40	
	63CWIR010060-010-DIP	1	6	2	60	10
	63CWIR010060-015-DIP	1	6	2	60	15
2	63CWIR02-DIP	2	3	6	40	
	63CWIRL02-DIP	2	3	15	75	
	63CWIRFL02-DIP	2	3	4	100	50
	63CWIR020060-010-DIP	2	6	2	60	10
	63CWIR020060-020-DIP	2	6	2	60	20
	63CWIR020060-030-DIP	2	6	2	60	30
3	63CWIR03-DIP	3	3	10	40	
	63CWIRL03-DIP	3	3	18	60	
	63CWIRFK03-DIP	3	3	6	40	15
	63CWIRF03-DIP	3	3	6	60	30
	63CWIRFL03-DIP	3	3	6	100	50
	63CWIR030060-015-DIP	3	6	5	60	15
	63CWIR030060-030-DIP	3	6	5	60	30
	63CWIR030060-040-DIP	3	6	5	75	40
	63CWIR030060-050-DIP	3	6	5	100	50
4	63CWIR04-DIP	4	4	11	40	
	63CWIRL04-DIP	4	4	20	60	
	63CWIRXL04-DIP	4	4	32	75	
	63CWIRF04-DIP	4	4	6	60	30
	63CWIRFL04-DIP	4	4	6	100	50
	63CWIR040060-020-DIP	4	6	6	60	20
	63CWIR040060-030-DIP	4	6	6	60	30
	63CWIR040060-040-DIP	4	6	6	75	40
	63CWIR040060-050-DIP	4	6	6	100	50
5	63CWIR05-DIP	5	5	13	50	
	63CWIRL05-DIP	5	5	25	62	
	63CWIRFL05-DIP	5	5	13	100	50
	63CWIR050060-030-DIP	5	6	8	60	30
	63CWIR050060-040-DIP	5	6	8	75	40
	63CWIR050060-050-DIP	5	6	8	100	50
6	63CWIR06-DIP	6	6	16	50	
	63CWIRL06-DIP	6	6	30	75	
	63CWIRF06-DIP	6	6	10	60	30
	63CWIR060060-040-DIP	6	6	10	75	40
	63CWIRFL06-DIP	6	6	10	100	50
	63CWIRFLV06-DIP	6	6	10	100	70
8	63CWIR08-DIP	8	8	19	63	
	63CWIRL08-DIP	8	8	35	75	
	63CWIR080080-030-DIP	8	8	12	63	30
	63CWIR080080-035-DIP	8	8	12	75	35
	63CWIR080080-040-DIP	8	8	12	75	40
	63CWIRFL08-DIP	8	8	12	100	50
	63CWIRFXL08-DIP	8	8	12	100	70
10	63CWIR10-DIP	10	10	22	72	
	63CWIRL10-DIP	10	10	40	89	
	63CWIRXL10-DIP	10	10	50	120	
	63CWIRFK10-DIP	10	10	15	72	35
	63CWIRF10-DIP	10	10	15	72	40
	63CWIRFL10-DIP	10	10	15	100	50
	63CWIRFXL10-DIP	10	10	15	100	70
	63CWIR100100-060-DIP	10	10	15	120	60
12	63CWIR120120-040-DIP	12	12	18	83	40
	63CWIRFL12-DIP	12	12	18	100	50
	63CWIRXL12-100-DIP	12	12	18	150	100
	63CWIRXL12-DIP	12	12	60	150	

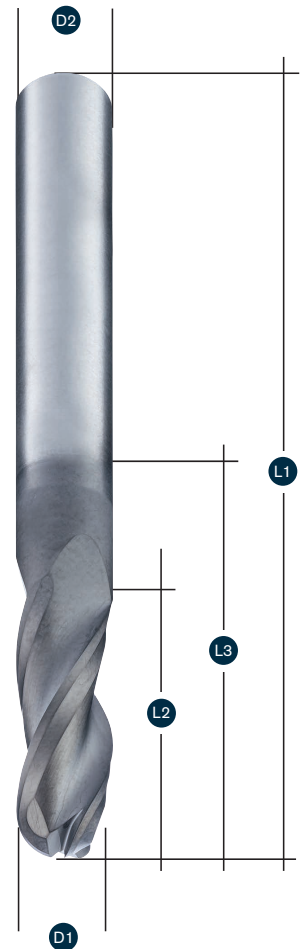

GRAPHIT LINE

→ Durchmesserbereich:
1,0 bis 12,0 mm

diameter range:
1,0 to 12,0 mm



PIRANHA END MILL 3F

GRAPHIT LINE

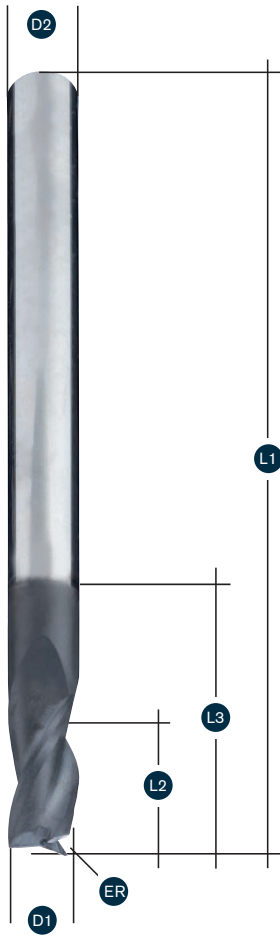

→ Durchmesserbereich:
2,0 bis 12,0 mm

diameter range:
2,0 to 12,0 mm



63CWI PIRANHA-FRÄSER

BESTELL-NUMMER ORDER NUMBER	D1 mm	D2 h6 mm	L2 mm	L1 mm	L3 mm	ER mm
2 63CWI02-DIP	2	3	6	40		0,30
63CWIS02-DIP	2	3	6	40		0,15
63CWIF0203-DIP	2	3	6	40	15	0,30
63CWIFK02-DIP	2	3	6	60	15	0,15
63CWIFK0203-DIP	2	3	6	60	15	0,30
63CWI020060-020-010-DIP	2	6	6	60	10	0,20
63CWI020060-020-020-DIP	2	6	6	60	20	0,20
63CWI020060-020-030-DIP	2	6	6	60	30	0,20
3 63CWI03-DIP	3	3	10	40		
63CWIS03-DIP	3	3	10	40		0,15
63CWIL03-DIP	3	3	18	60		
63CWISL03-DIP	3	3	18	60		0,15
63CWIF0305-DIP	3	3	6	40	15	0,5
63CWIFK0305-DIP	3	3	6	60	30	0,5
63CWIFL03-DIP	3	3	6	100	50	0,5
63CWI030060-020-015-DIP	3	6	5	60	15	0,2
63CWI030060-020-030-DIP	3	6	5	60	30	0,2
63CWI030060-020-040-DIP	3	6	5	75	40	0,2
63CWI030060-020-050-DIP	3	6	5	100	50	0,2
4 63CWI04-DIP	4	4	11	40		
63CWIS04-DIP	4	4	11	40		0,20
63CWIL04-DIP	4	4	20	60		
63CWISL04-DIP	4	4	20	60		0,20
63CWIFL0405-DIP	4	4	6	40	15	0,50
63CWIFK0405-DIP	4	4	6	60	30	0,50
63CWIFL04-DIP	4	4	6	100	50	0,50
63CWI040060-050-020-DIP	4	6	6	60	20	0,50
63CWI040060-050-030-DIP	4	6	6	60	30	0,50
63CWI040060-050-040-DIP	4	6	6	75	40	0,50
63CWI040060-050-050-DIP	4	6	6	100	50	0,50
5 63CWIL05-DIP	5	5	25	62		
63CWIF0505-DIP	5	5	6	50	15	0,5
63CWI050060-050-030-DIP	5	6	8	60	30	0,5
63CWI050060-050-040-DIP	5	6	8	75	40	0,5
63CWI050060-050-050-DIP	5	6	8	100	50	0,5

PIRANHA END MILL 3F

63CWI PIRANHA-FRÄSER							
	BESTELL-NUMMER ORDER NUMBER	D1 mm	D2 h6 mm	L2 mm	L1 mm	L3 mm	ER mm
6	63CWI06-DIP	6	6	16	50		
	63CWI06-DIP	6	6	16	50		0,3
	63CWI06-DIP	6	6	30	75		
	63CWI06-DIP	6	6	30	75		0,3
	63CWI06-DIP	6	6	10	60	30	0,5
	63CWI06-DIP	6	6	10	60	30	1
	63CWI06-DIP	6	6	10	75	40	0,5
	63CWI06-DIP	6	6	10	75	40	1
	63CWI06-DIP	6	6	10	100	50	0,5
	63CWI06-DIP	6	6	10	100	50	1
8	63CWI080080-050-030-DIP	8	8	12	63	30	0,5
	63CWI080080-100-030-DIP	8	8	12	63	30	1
	63CWI080080-DIP	8	8	10	75	35	0,5
	63CWI080080-DIP	8	8	10	75	35	1
	63CWI080080-050-040-DIP	8	8	12	75	40	0,5
	63CWI080080-100-040-DIP	8	8	12	75	40	1
	63CWI080080-DIP	8	8	10	100	50	0,5
	63CWI080080-DIP	8	8	10	100	50	1
10	63CWI10-DIP	10	10	40	89		
	63CWI10-DIP	10	10	50	120		
	63CWI100100-050-035-DIP	10	10	15	72	35	0,5
	63CWI100100-100-035-DIP	10	10	15	72	35	1,0
	63CWI100100-DIP	10	10	15	72	40	0,5
	63CWI100100-DIP	10	10	15	72	40	1,0
	63CWI100100-DIP	10	10	15	100	50	0,5
	63CWI100100-DIP	10	10	15	100	50	1,0
	63CWI100100-050-060-DIP	10	10	22	120	60	0,5
	63CWI100100-100-060-DIP	10	10	22	120	60	1,0
12	63CWI12-DIP	12	12	26	83		
	63CWI12-DIP	12	12	50	100		
	63CWI1205-DIP	12	12	18	83	40	0,5
	63CWI1210-DIP	12	12	18	83	40	1,0
	63CWI1205-DIP	12	12	18	100	50	0,5
	63CWI1210-DIP	12	12	18	100	50	1,0
	63CWI1205-DIP	12	12	18	125	70	0,5
	63CWI1210-DIP	12	12	18	125	70	1,0
	63CWI120120-050-100-DIP	12	12	18	150	100	0,5
	63CWI120120-100-100-DIP	12	12	18	150	100	1,0

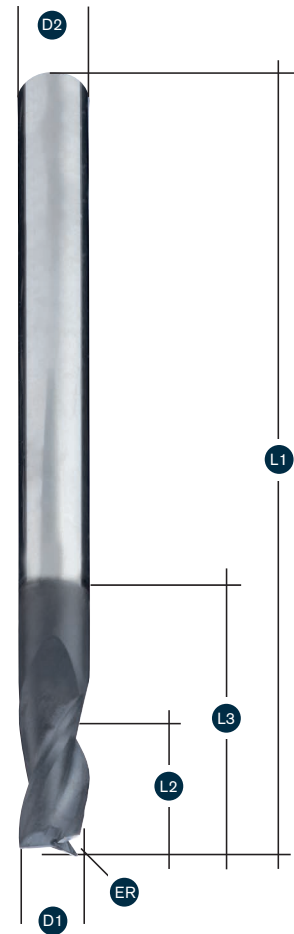

GRAPHIT LINE

→ Durchmesserbereich:
2,0 bis 12,0 mm
diameter range:
2,0 to 12,0 mm

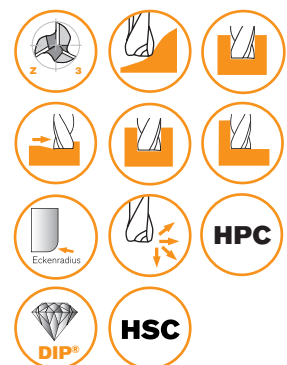

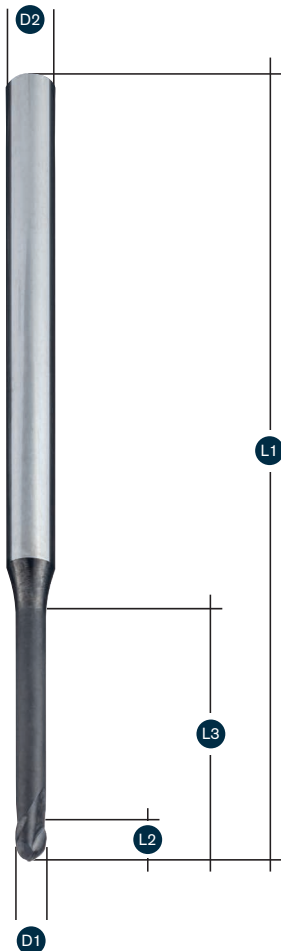

→ Durchmesserbereich:
0,2 bis 2,0 mm

diameter range:
0,2 to 2,0 mm



HM915 MINI-KUGELFRÄSER (KOPFRADIUS R = 0,5 X D1)

BESTELL-NUMMER ORDER NUMBER	D1 mm	D2 h6 mm	L2 mm	L1 mm	L3 mm	
0,2	HM915MFE002-DIP	0,2	6	0,3	60	
0,3	HM915M0032-DIP	0,3	3	0,5	40	
	HM915MF003-DIP	0,3	4	0,3	50	
	HM915MFL003-DIP	0,3	4	0,3	50	
	HM915003060-030-DIP	0,3	6	0,3	50	
	HM915003060-060-DIP	0,3	6	0,3	50	
0,4	HM915M0042-DIP	0,4	3	0,6	40	
	HM915MF004-DIP	0,4	4	0,4	50	
	HM915MFZ004-DIP	0,4	4	0,4	50	
	HM915MFL004-DIP	0,4	4	0,4	50	
	HM915004060-040-DIP	0,4	6	0,4	50	
	HM915004060-080-DIP	0,4	6	0,4	50	
0,5	HM915ML0052-DIP	0,5	4	1,5	50	
	HM915L005-DIP	0,5	3	0,5	40	
	HM915XL005-DIP	0,5	3	0,5	40	
	HM915005040-025-DIP	0,5	4	0,5	50	
	HM915MF005-DIP	0,5	4	0,5	50	
	HM915MFVL005-DIP	0,5	4	0,5	50	
	HM915MFL005-DIP	0,5	4	0,5	50	
	HM915005060-025-DIP	0,5	6	0,5	50	
	HM915005060-050-DIP	0,5	6	0,5	50	
	HM915005060-075-DIP	0,5	6	0,5	50	
	HM915005060-100-DIP	0,5	6	0,5	50	
	HM915MFEL005-DIP	0,5	6	0,5	60	
	HM915MFEXL005-DIP	0,5	6	0,5	60	
	0,6	HM915ML0062-DIP	0,6	4	1,8	50
		HM915L006-DIP	0,6	3	0,6	40
HM915XL006-DIP		0,6	3	0,6	40	
HM915006040-030-DIP		0,6	4	0,6	50	
HM915006040-060-DIP		0,6	4	0,6	50	
HM915MFZ006-DIP		0,6	4	0,6	50	
HM915MFVL006-DIP		0,6	4	0,6	50	
HM915MFL006-DIP		0,6	4	0,6	50	
HM915006060-030-DIP		0,6	6	0,6	50	
HM915006060-060-DIP		0,6	6	0,6	50	
HM915006060-090-DIP		0,6	6	0,6	50	
HM915006060-120-DIP		0,6	6	0,6	50	
HM915MFEL006-DIP		0,6	6	0,6	60	
HM915MFEXL006-DIP		0,6	6	0,6	60	
0,8		HM915M0082-DIP	0,8	3	1,2	40
	HM915ML0082-DIP	0,8	4	2,4	50	
	HM915L008-DIP	0,8	3	0,8	40	
	HM915XL008-DIP	0,8	3	0,8	40	
	HM915MF008-DIP	0,8	4	0,8	50	
	HM915MFZ008-DIP	0,8	4	0,8	50	
	HM915MFL008-DIP	0,8	4	0,8	50	
	HM915MFVL008-DIP	0,8	4	0,8	50	
	HM915MFXL008-DIP	0,8	4	0,8	50	
	HM915008040-040-DIP	0,8	4	0,8	60	
	HM915008040-080-DIP	0,8	4	0,8	60	
	HM915008040-120-DIP	0,8	4	0,8	60	
	HM915008040-160-DIP	0,8	4	0,8	60	
	HM915008060-040-DIP	0,8	6	0,8	60	
	HM915MFEL008-DIP	0,8	6	0,8	60	
	HM915MFEXL008-DIP	0,8	6	0,8	60	
	HM915008060-120-DIP	0,8	6	0,8	60	
	HM915008060-160-DIP	0,8	6	0,8	60	

MINI-KUGELFRÄSER Z2

zentrumschneidend/Kopfradius R = 0,5 x D1

HM915

MINI-BALL END MILL 2F

center cutting/ball radius R = 0,5 x D1

HM915 MINI-KUGELFRÄSER (KOPFRADIUS R = 0,5 X D1)

	BESTELL-NUMMER ORDER NUMBER	D1 mm	D2 h6 mm	L2 mm	L1 mm	L3 mm
1	HM915M0102-DIP	1,0	3	1,5	38	
	HM915ML0102-DIP	1,0	4	3,0	50	
	HM915L010-DIP	1,0	3	1,0	40	5
	HM915XL010-DIP	1,0	3	1,0	40	8,5
	HM915MFZ010-DIP	1,0	4	1,0	50	10
	HM915MFVL010-DIP	1,0	4	1,0	50	15
	HM915MFZL010-DIP	1,0	4	1,0	50	20
	HM915010040-050-DIP	1,0	4	1,0	60	5
	HM915010040-100-DIP	1,0	4	1,0	60	10
	HM915010040-150-DIP	1,0	4	1,0	60	15
	HM915010040-200-DIP	1,0	4	1,0	60	20
	HM915010060-050-DIP	1,0	6	1,0	60	5
	HM915MF010-DIP	1,0	6	1,0	60	6
	HM915MFEL010-DIP	1,0	6	1,0	60	8
	HM915010060-100-DIP	1,0	6	1,0	60	10
	HM915MFL010-DIP	1,0	6	1,0	60	11
	HM915MFEXL010-DIP	1,0	6	1,0	60	15
	HM915MFXL010-DIP	1,0	6	1,0	60	20
1,2	HM915L012-DIP	1,2	3	1,2	40	6
	HM915XL012-DIP	1,2	3	1,2	40	10
	HM915012040-060-DIP	1,2	4	1,2	60	6
	HM915012040-120-DIP	1,2	4	1,2	60	12
	HM915012060-060-DIP	1,2	6	1,2	60	6
	HM915012060-120-DIP	1,2	6	1,2	60	12
1,5	HM915M0152-DIP	1,5	3	2,3	38	
	HM915ML0152-DIP	1,5	4	4,2	50	
	HM915L015-DIP	1,5	3	1,5	40	7,5
	HM915XL015-DIP	1,5	3	1,5	40	12
	HM915SL015-DIP	1,5	3	1,5	40	16
	HM915MFZ015-DIP	1,5	4	1,5	50	16
	HM915MFVL015-DIP	1,5	4	1,5	50	20
	HM915015040-075-DIP	1,5	4	1,5	60	7,5
	HM915015040-150-DIP	1,5	4	1,5	60	15
	HM915015040-250-DIP	1,5	4	1,5	60	25
	HM915015060-075-DIP	1,5	6	1,5	60	7,5
	HM915MFL015-DIP	1,5	6	1,5	60	15
	HM915MFXL015-DIP	1,5	6	1,5	60	20
	HM915015060-250-DIP	1,5	6	1,5	60	25
2	HM915L020-DIP	2,0	3	2,0	50	12
	HM915XL020-DIP	2,0	3	2,0	50	16
	HM915SL020-DIP	2,0	3	2,0	50	20
	HM915020040-100-DIP	2,0	4	2,0	60	10
	HM915MFA020-DIP	2,0	4	2,0	60	15
	HM915MFZ020-DIP	2,0	4	2,0	60	20
	HM915020040-300-DIP	2,0	4	2,0	75	30
	HM915020040-400-DIP	2,0	4	2,0	75	40
	HM915MFEL020-DIP	2,0	6	2,0	60	10
	HM915MFL020-DIP	2,0	6	2,0	60	15
	HM915MFXL020-DIP	2,0	6	2,0	60	20
	HM915MFZL020-DIP	2,0	6	2,0	75	30
	HM915020060-400-DIP	2,0	6	2,0	75	40

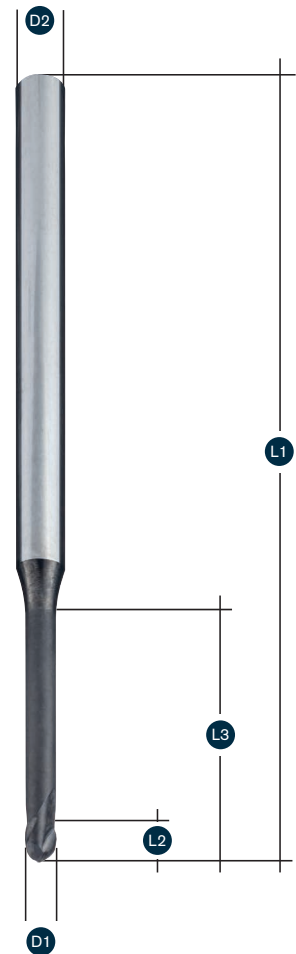

GRAPHIT LINE

➔ Durchmesserbereich:
0,2 bis 2,0 mm

diameter range:
0,2 to 2,0 mm



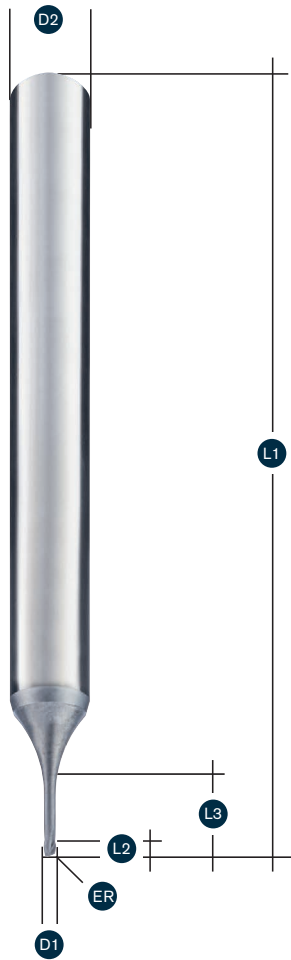

→ Durchmesserbereich:
0,2 bis 2,0 mm

diameter range:
0,2 to 2,0 mm



HM905 MINI-TORUSFRÄSER

	BESTELL-NUMMER ORDER NUMBER	D1 mm	D2 h6 mm	L2 mm	L1 mm	L3 mm	ER mm
0,2	HM905M0022-DIP	0,2	3	0,4	40		
	HM905ML0022-DIP	0,2	4	0,4	50		
0,3	HM905M0032-DIP	0,3	3	0,9	40		
	HM905ML0032-DIP	0,3	4	0,9	50		
0,4	HM905M0042-DIP	0,4	3	1,2	40		
	HM905ML0042-DIP	0,4	4	1,2	50		
	HM905MFL004-DIP	0,4	4	0,5	50	2	0,05
	HM905MFZL004-DIP	0,4	4	0,5	50	4	0,05
	HM905MFEL004-DIP	0,4	6	0,5	60	1,2	0,05
	HM905MFEXL004-DIP	0,4	6	0,5	60	4	0,05
0,5	HM905M0052-DIP	0,5	3	1,5	40		
	HM905L005-DIP	0,5	3	0,7	40	2,5	0,05
	HM905XL005-DIP	0,5	3	0,7	40	4	0,05
	HM905MF005-DIP	0,5	4	0,7	50	5	0,05
	HM905MFZL005-DIP	0,5	4	0,7	50	7,5	0,05
	HM905MFL005-DIP	0,5	4	0,7	50	10	0,05
	HM905005040-010-025-DIP	0,5	4	0,7	50	2,5	0,10
	HM905005040-010-050-DIP	0,5	4	0,7	50	5	0,10
	HM905005040-010-075-DIP	0,5	4	0,7	50	7,5	0,10
	HM905005040-010-100-DIP	0,5	4	0,7	50	10	0,10
	HM905005060-010-025-DIP	0,5	6	0,7	50	2,5	0,10
	HM905MFEXL005-DIP	0,5	6	0,7	60	5	0,10
	HM905005060-010-075-DIP	0,5	6	0,7	60	7,5	0,10
	HM905005060-010-100-DIP	0,5	6	0,7	60	10	0,10
0,6	HM905M0062-DIP	0,6	3	1,8	40		
	HM905L006-DIP	0,6	3	0,9	40	3	0,05
	HM905XL006-DIP	0,6	3	0,9	40	5	0,05
	HM905MFZ006-DIP	0,6	4	0,8	50	7	0,05
	HM905MFZL006-DIP	0,6	4	0,8	50	9	0,05
	HM905MFL006-DIP	0,6	4	0,8	50	12	0,05
	HM905006040-010-030-DIP	0,6	4	0,8	50	3	0,10
	HM905006040-010-060-DIP	0,6	4	0,8	50	6	0,10
	HM905006040-010-090-DIP	0,6	4	0,8	50	9	0,10
	HM905006040-010-120-DIP	0,6	4	0,8	50	12	0,10
	HM905006060-010-030-DIP	0,6	6	0,8	60	3	0,10
	HM905MFEXL006-DIP	0,6	6	1,0	60	6	0,10
	HM905006060-010-090-DIP	0,6	6	0,8	60	9	0,10
	HM905006060-010-120-DIP	0,6	6	0,8	60	12	0,10
0,8	HM905M0082-DIP	0,8	3	2,4	40		
	HM905L008-DIP	0,8	3	1,2	40	4	0,05
	HM905XL008-DIP	0,8	3	1,2	40	7	0,05
	HM905008040-010-040-DIP	0,8	4	0,8	50	4	0,1
	HM905MFZ008-DIP	0,8	4	0,8	50	8	0,1
	HM905MFL008-DIP	0,8	4	0,8	50	10	0,1
	HM905MFZL008-DIP	0,8	4	0,8	50	12	0,1
	HM905MFXL008-DIP	0,8	4	0,8	50	16	0,1
	HM905008060-010-040-DIP	0,8	6	1	60	4	0,1
	HM905008060-010-080-DIP	0,8	6	1	60	8	0,1
HM905008060-010-120-DIP	0,8	6	1	60	12	0,1	
HM905008060-010-160-DIP	0,8	6	1	60	16	0,1	

MINI-TORIC END MILL 2F

center cutting

HM905 MINI-TORUSFRÄSER

	BESTELL-NUMMER ORDER NUMBER	D1 mm	D2 h6 mm	L2 mm	L1 mm	L3 mm	ER mm
1	HM905M0102-DIP	1,0	3	3,0	40		
	HM905L010-DIP	1,0	3	1,5	40	5	0,1
	HM905XL010-DIP	1,0	3	1,5	40	8,5	0,1
	HM905MFZL010-DIP	1,0	4	1,5	50	10	0,1
	HM905MFSL010-DIP	1,0	4	1,5	50	15	0,1
	HM905MFZXL010-DIP	1,0	4	1,5	50	20	0,1
	HM905010040-020-050-DIP	1,0	4	1,2	60	5	0,2
	HM905010040-020-100-DIP	1,0	4	1,2	60	10	0,2
	HM905010040-020-150-DIP	1,0	4	1,2	60	15	0,2
	HM905010040-020-200-DIP	1,0	4	1,2	60	20	0,2
	HM905MF010-DIP	1,0	6	1,2	60	5	0,1
	HM905MFL010-DIP	1,0	6	1,2	60	10	0,1
	HM905MFXL010-DIP	1,0	6	1,2	60	20	0,1
	HM905010060-020-050-DIP	1,0	6	1,2	60	5	0,2
	HM905010060-020-100-DIP	1,0	6	1,2	60	10	0,2
	HM905010060-020-150-DIP	1,0	6	1,2	60	15	0,2
	HM905010060-020-200-DIP	1,0	6	1,2	60	20	0,2
1,2	HM905ML0122-DIP	1,2	4	3,8	50		0,1
	HM905L012-DIP	1,2	3	1,8	40	6	0,1
	HM905XL012-DIP	1,2	3	1,8	40	10	0,1
	HM905012040-020-060-DIP	1,2	4	1,2	60	6	0,2
	HM905012040-020-120-DIP	1,2	4	1,2	60	12	0,2
	HM905012060-020-060-DIP	1,2	6	1,2	60	6	0,2
	HM905012060-020-120-DIP	1,2	6	1,2	60	12	0,2
1,5	HM905M0152-DIP	1,5	3	4,2	40		
	HM905L015-DIP	1,5	3	2,2	40	7,5	0,15
	HM905XL015-DIP	1,5	3	2,2	40	12	0,15
	HM905MFZL015-DIP	1,5	4	2,2	50	15	0,15
	HM905MFSL015-DIP	1,5	4	2,2	50	20	0,15
	HM905MFZXL015-DIP	1,5	4	2,2	60	25	0,15
	HM905015040-020-075-DIP	1,5	4	1,7	60	7,5	0,2
	HM905015040-020-120-DIP	1,5	4	1,7	60	12	0,2
	HM905015040-020-150-DIP	1,5	4	1,7	60	15	0,2
	HM905015040-020-200-DIP	1,5	4	1,7	60	20	0,2
	HM905015060-020-075-DIP	1,5	6	1,7	60	7,5	0,2
	HM905015060-020-120-DIP	1,5	6	1,7	60	12	0,2
	HM905015060-020-150-DIP	1,5	6	1,7	60	15	0,2
	HM905015060-020-200-DIP	1,5	6	1,7	60	20	0,2
2	HM905M0202-DIP	2,0	3	6,0	40		
	HM905ML0202-DIP	2,0	4	6,0	50		
	HM905LE020-DIP	2,0	3	4,0	50	12	0,2
	HM905XL020-DIP	2,0	3	4,0	50	16	0,2
	HM905SL020-DIP	2,0	3	4,0	50	20	0,2
	HM905020040-020-100-DIP	2,0	4	2,2	60	10	0,2
	HM905020040-020-150-DIP	2,0	4	2,2	60	15	0,2
	HM905MFZL020-DIP	2,0	4	2,2	60	20	0,2
	HM905020040-020-300-DIP	2,0	4	2,2	75	30	0,2
	HM905020040-020-400-DIP	2,0	4	2,2	75	40	0,2
	HM905020060-020-100-DIP	2,0	6	2,2	60	10	0,2
	HM905MFL020-DIP	2,0	6	2,2	60	15	0,2
	HM905020060-020-200-DIP	2,0	6	2,2	60	20	0,2
	HM905MFXL020-DIP	2,0	6	2,2	75	30	0,2
	HM905020060-020-400-DIP	2,0	6	2,2	75	40	0,2



GRAPHIT LINE

→ Durchmesserbereich:
0,2 bis 2,0 mm

diameter range:
0,2 to 2,0 mm



BALL END MILL 2F

ball radius R = 0,5 x D1

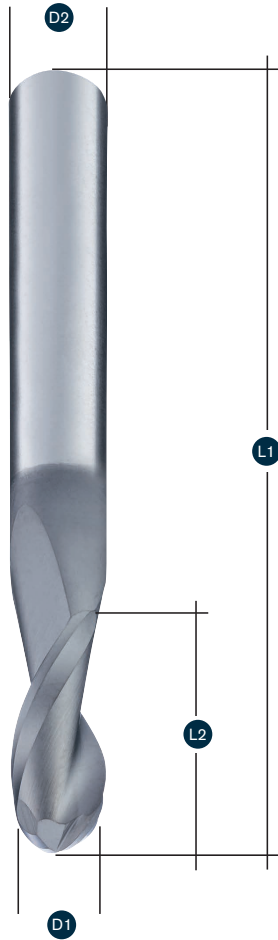

→ Durchmesserbereich:
1,0 bis 12,0 mm

diameter range:
1,0 to 12,0 mm



97DC KUGELFRÄSER

BESTELL-NUMMER ORDER NUMBER		D1 mm	D2 h6 mm	L2 mm	L1 mm	L3 mm
1,0	97DC01	1	3	5	40	
1,5	97DC015	1,5	3	6	40	
2,0	97DC02	2	3	6	40	
	97DCL02	2	3	15	75	
2,5	97DC025	2,5	3	7	40	
3,0	97DC03	3	3	8	40	
	97DCL03	3	3	18	60	
	97DCXL03	3	3	25	75	
	97DCF03	3	3	6	40	15
	97DCFL03	3	3	6	60	30
	97DCFSL03	3	3	10	100	70
	97DMB03	3	6	3	60	15
4,0	97DC04	4	4	10	40	
	97DCL04	4	4	20	60	
	97DCXL04	4	4	32	75	
	97DCF04	4	4	6	40	15
	97DCFL04	4	4	6	60	30
	97DCFSL04	4	4	12	100	70
	97DMB04	4	6	4	60	15
5,0	97DC05	5	5	12	50	
	97DCL05	5	5	25	62	
	97DCXL05	5	5	38	100	
	97DCF05	5	5	8	50	25
	97DCFL05	5	5	8	75	40
	97DMB05	5	6	5	60	15
	97DCFSL05	5	6	15	100	70
6,0	97DC06	6	6	14	50	
	97DCL06	6	6	30	75	
	97DCXL06	6	6	40	100	
	97DCF06	6	6	10	50	25
	97DCFL06	6	6	10	100	70
	97DCFSL06	6	6	25	150	100
	97DCFXL06	6	6	40	200	150
8,0	97DC08	8	8	16	63	
	97DCL08	8	8	35	75	
	97DCXL08	8	8	45	100	
	97DCF08	8	8	10	75	35
	97DCFL08	8	8	10	100	70
	97DCFXL08	8	8	25	200	120
	97DCFSL08	8	10	25	150	100

BALL END MILL 2F

ball radius R = 0,5 x D1

97DC KUGELFRÄSER

BESTELL-NUMMER ORDER NUMBER		D1 mm	D2 h6 mm	L2 mm	L1 mm	L3 mm
10,0	97DC10	10	10	19	72	
	97DCL10	10	10	40	89	
	97DCXL10	10	10	50	120	
	97DCF10	10	10	10	72	40
	97DCFL10	10	10	10	100	70
	97DCFXL10	10	10	50	200	120
	97DCFSL10	10	12	25	150	100
12,0	97DC12	12	12	22	83	
	97DCL12	12	12	50	100	
	97DCXL12	12	12	60	150	
	97DCF12	12	12	10	83	40
	97DCFL12	12	12	10	100	70
	97DCFSL12	12	12	25	150	100
	97DCFXL12	12	12	50	200	120

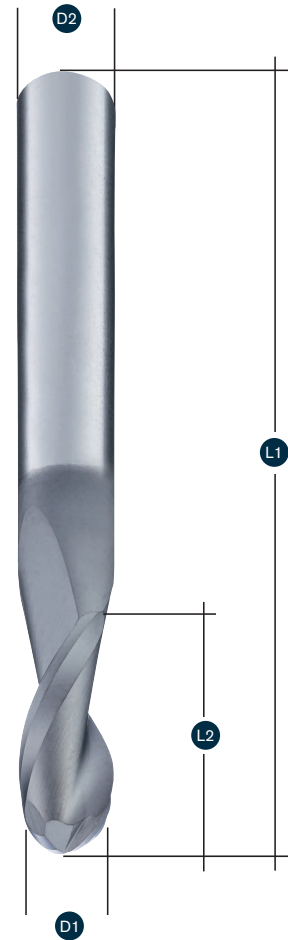

GRAPHIT LINE

→ Durchmesserbereich:
1,0 bis 12,0 mm

diameter range:
1,0 to 12,0 mm



END MILL 2F

center cutting

GRAPHIT LINE

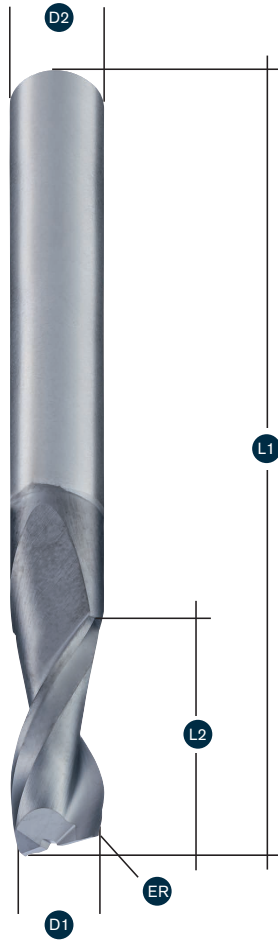

→ Durchmesserbereich:
1,0 bis 20,0 mm

diameter range:
1,0 to 20,0 mm



93DC SCHAFTFRÄSER

BESTELL-NUMMER ORDER NUMBER	D1 mm	D2 h6 mm	L2 mm	L1 mm	L3 mm	ER mm
1,0 93DC01	1	3	5	40		
1,5 93DC015	1,5	3	6	40		
2,0 93DC02	2	3	6	40		
93DCR0202	2	3	8	40		0,2
93DCL02	2	3	15	75		
93DCFHS02	2	3	10	100	20	0,2
3,0 93DC03	3	3	8	40		
93DCR0303	3	3	10	40		0,3
93DCL03	3	3	18	60		
93DCRL0303	3	3	30	60		0,3
93DCXL03	3	3	25	75		
93DCF0305	3	3	6	40	15	0,5
93DCFL0305	3	3	6	60	30	0,5
93DCFHS03	3	3	15	100	30	0,3
93DMRL03025	3	6	3	60	15	0,25
4,0 93DC04	4	4	10	40		
93DCR0405	4	4	15	60		0,5
93DCL04	4	4	20	60		
93DCRL0405	4	4	30	60		0,5
93DCXL04	4	4	32	75		
93DCF0405	4	4	6	40	15	0,5
93DCFL0405	4	4	6	60	30	0,5
93DCFHS04	4	4	20	100	40	0,3
93DMRL04025	4	6	4	60	15	0,25
5,0 93DC05	5	5	12	50		
93DCR0505	5	5	20	50		0,5
93DCL05	5	5	25	62		
93DCRL0505	5	5	35	75		0,5
93DCXL05	5	5	38	100		
93DCF0505	5	5	6	40	15	0,5
93DMRL0505	5	5	5	60	15	0,5
93DCFL0505	5	5	6	75	40	0,5
93DCFHS05	5	5	25	100	70	0,5
6,0 93DC06	6	6	14	50		
93DCR0605	6	6	20	60		0,5
93DCL06	6	6	30	75		
93DCXL06	6	6	40	100		
93DCRL0605	6	6	40	100		0,5
SLYLDC06	6	6	25	200		0,3
93DCF0605	6	6	10	60	30	0,5
93DCF0610	6	6	10	60	30	1,0
93DCFL0605	6	6	10	100	70	0,5
93DCFL0610	6	6	10	100	70	1,0
93DCFHS06	6	6	35	150	80	0,5
SLYFDC06	6	6	25	200	120	0,3

END MILL 2F

center cutting

93DC SCHAFTFRÄSER							
BESTELL-NUMMER ORDER NUMBER	D1 mm	D2 h6 mm	L2 mm	L1 mm	L3 mm	ER mm	
8,0	93DC08	8	8	19	63		
	93DCR0805	8	8	20	75		0,5
	93DCR0810	8	8	20	75		1,0
	93DCL08	8	8	35	75		
	93DCRL0805	8	8	40	100		0,5
	93DCRL0810	8	8	40	100		1,0
	93DCXL08	8	8	45	100		
	93DCRXL0810	8	8	25	150		1,0
	93DCF0805	8	8	10	75	35	0,5
	93DCF0810	8	8	10	75	35	1,0
	93DCFLO805	8	8	10	100	70	0,5
	93DCFLO810	8	8	10	100	70	1,0
	93DCFLO8210	8	8	25	150	100	1,0
	93DCFHS08	8	8	40	150	90	0,5
10,0	93DC10	10	10	20	72		
	93DCR1005	10	10	25	80		0,5
	93DCR1010	10	10	25	80		1,0
	93DCL10	10	10	40	80		
	93DCRL1005	10	10	40	100		0,5
	93DCRL1010	10	10	40	100		1,0
	93DCXL10	10	10	50	120		
	93DCRXL1010	10	10	25	150		1,0
	93DCF1005	10	10	10	72	40	0,5
	93DCF1010	10	10	10	72	40	1,0
	93DCFLO1005	10	10	10	100	70	0,5
	93DCFLO1010	10	10	10	100	70	1,0
	93DCFLO10210	10	10	25	150	100	1,0
	SLYFDC10	10	10	50	200	120	0,5
12,0	93DCR1210	12	12	25	100		1,0
	93DCL12	12	12	50	100		
	93DCRXL1210	12	12	30	150		1,0
	93DCXL12	12	12	60	150		
	SLYLDC12	12	12	50	200		0,6
	93DCF1205	12	12	10	83	40	0,5
	93DCF1210	12	12	10	83	40	1,0
	93DCFLO1205	12	12	10	100	70	0,5
	93DCFLO1210	12	12	10	100	70	1,0
	93DCFLO12310	12	12	30	150	100	1,0
	SLYFDC12	12	12	50	200	120	0,6
16,0	93DC16	16	16	26	92		
	93DCL16	16	16	58	125		
	SLYFDC16	16	16	65	200	150	0,8
20,0	93DC20	20	20	32	104		
	93DCL20	20	20	60	125		
	93DCXL20	20	20	75	150		

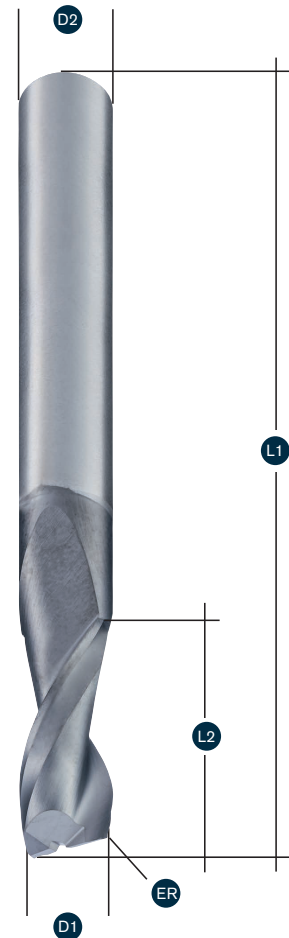

GRAPHIT LINE

→ Durchmesserbereich:
1,0 bis 20,0 mm

diameter range:
1,0 to 20,0 mm



BALL END MILL 2F - CONIC

ball radius R = 0,5 x D1

GRAPHIT-LINE

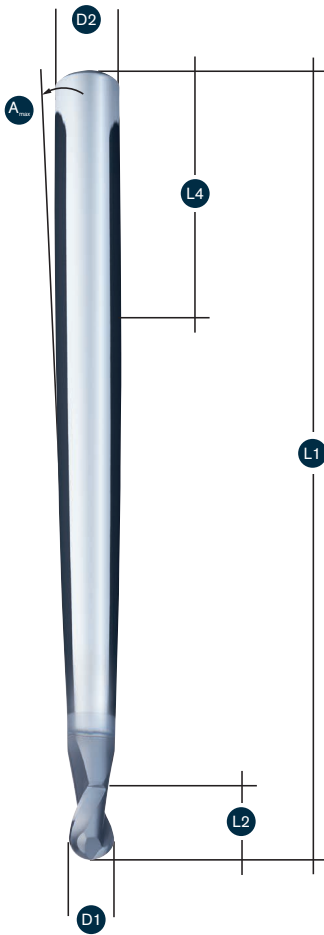

→ Durchmesserbereich:
1,0 bis 12,0 mm

diameter range:
1,0 to 12,0 mm



97DCSK KUGELFRÄSER

	BESTELL-NUMMER ORDER NUMBER	D1 mm	D2 h6 mm	L2 mm	L1 mm	L4 mm	A _{max} °
1,0	97DCSKR01	1	4	2	50	30	5,5
	97DCSKRL01	1	6	2	57	30	6,4
	97DCSKK01	1	6	2	80	30	1,9
	97DCSK04010	1	6	2	100	30	0,45
	97DCSK09010	1	6	2	100	30	0,95
1,5	97DCSKR015	1,5	4	2,5	50	30	5,0
	97DCSKRL015	1,5	6	2,5	57	30	6,0
	97DCSK04015	1,5	6	3	100	30	0,45
	97DCSK09015	1,5	6	3	100	30	0,95
2,0	97DCSKR02	2	4	3	50	30	4,3
	97DCSKRL02	2	6	3	57	30	5,6
	97DCSKK02	2	6	3	80	30	1,9
	97DCSK04020	2	6	4	100	30	0,45
	97DCSK09020	2	6	4	100	30	0,95
2,5	97DCSKR025	2,5	4	3,5	50	30	3,5
	97DCSKRL025	2,5	6	3,5	57	30	5,2
	97DCSK04025	2,5	6	4	100	30	0,45
	97DCSK09025	2,5	6	4	100	30	0,95
3,0	97DCSKR03	3	4	3,5	50	30	2,5
	97DCSKRL03	3	4	6	80	30	2,9
	97DCSK04030	3	6	6	100	30	0,45
	97DCSK09030	3	6	6	100	30	0,95
4,0	97DCSKR04	4	6	6	80	30	2,3
	97DCSK04040	4	6	6	100	30	0,45
	97DCSK09040	4	6	6	100	30	0,95
	97DCSKXLS04	4	6	12	150	30	0,6
5,0	97DCSKR05	5	6	7	80	30	1,4
	97DCSK05	5	6	15	100	30	0,6
6,0	97DCSKR06	6	8	9	100	40	1,5
	97DCSK06	6	8	25	150	30	0,6
	97DCSKRL06	6	10	9	100	50	2,3
8,0	97DCSKR08	8	10	12	120	50	1,4
	97DCSKRL08	8	12	12	150	60	1,9
10,0	97DCSKR10	10	12	14	150	60	1,1
12,0	97DCSKR12	12	16	16	150	60	2,1

TORIC END MILL 2F

conic - center cutting

93DCSK TORUSFRÄSER								
BESTELL-NUMMER ORDER NUMBER	D1 mm	D2 h6 mm	L2 mm	L1 mm	L4 mm	ER mm	A _{max} °	
1,0	93DCSKR01	1	4	2	50	30	0,1	5,5
	93DCSKRL01	1	6	2	57	30	0,1	6,4
	93DCSKK01	1	6	2	80	30	0,25	1,9
	93DCSK04010	1	6	2	100	30	0,2	0,45
	93DCSK09010	1	6	2	100	30	0,2	0,95
1,5	93DCSKR015	1,5	4	2,5	50	30	0,1	5,0
	93DCSKRL015	1,5	6	2,5	57	30	0,1	6,0
	93DCSK04015	1,5	6	3	100	30	0,2	0,45
	93DCSK09015	1,5	6	3	100	30	0,2	1,0
2,0	93DCSKR02	2	4	3	50	30	0,2	4,3
	93DCSKRL02	2	6	3	57	30	0,2	5,6
	93DCSKK02	2	6	3	80	30	0,5	1,9
	93DCSK04020	2	6	4	100	30	0,5	0,45
	93DCSK09020	2	6	4	100	30	0,5	1,0
2,5	93DCSKR025	2,5	4	3,5	50	30	0,3	3,5
	93DCSKRL025	2,5	6	3,5	57	30	0,3	5,2
	93DCSK04025	2,5	6	4	100	30	0,5	0,45
	93DCSK09025	2,5	6	4	100	30	0,5	1,0
3,0	93DCSKR03	3	4	3,5	50	30	0,5	2,5
	93DCSKRL03	3	4	6	80	30	0,5	2,9
	93DCSK04030	3	6	6	100	30	0,5	0,45
	93DCSK09030	3	6	6	100	30	0,5	1,0
4,0	93DCSKR04	4	6	6	80	30	0,5	2,3
	93DCSK04040	4	6	6	100	30	0,5	0,5
	93DCSK09040	4	6	6	100	30	0,5	1,0
	93DCSKXLS04	4	6	12	150	30	0,5	0,6
5,0	93DCSKR05	5	6	7	80	30	0,5	1,4
	93DCSK05	5	6	15	100	30	0,5	0,6
6,0	93DCSKR06	6	8	9	100	40	1	1,5
	93DCSK06	6	8	25	150	30	1	0,6
	93DCSKRL06	6	10	9	100	50	1	2,3
8,0	93DCSKR08	8	10	12	120	50	1	1,4
	93DCSKRL08	8	12	12	150	60	1	1,9
10,0	93DCSKR10	10	12	14	150	60	1	1,1
12,0	93DCSKR12	12	16	16	150	60	1,5	2,1



GRAPHIT LINE

→ Durchmesserbereich:
1,0 bis 12,0 mm

diameter range:
1,0 to 12,0 mm



BALL END MILL 4F

ball radius R = 0,5 x D1

GRAPHIT
LINE

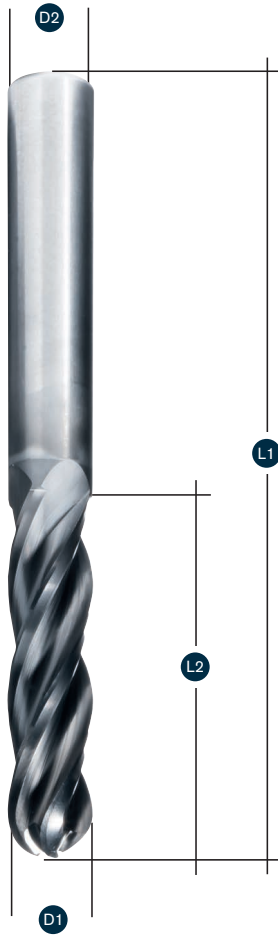

95DC KUGELFRÄSER

BESTELL-NUMMER ORDER NUMBER		D1 mm	D2 h6 mm	L2 mm	L1 mm
2,0	95DC02	2	3	6	40
2,5	95DC025	2,5	3	7	40
3,0	95DC03	3	3	10	40
	95DCL03	3	3	18	60
	95DCXL03	3	3	25	75
4,0	95DC04	4	4	11	40
	95DCL04	4	4	20	60
	95DCXL04	4	4	32	75
5,0	95DC05	5	5	13	50
	95DCL05	5	5	25	62
	95DCXL05	5	5	38	100
6,0	95DC06	6	6	16	50
	95DCL06	6	6	30	70
	95DCXL06	6	6	40	100
8,0	95DC08	8	8	19	63
	95DCL08	8	8	35	75
	95DCXL08	8	8	45	100
10,0	95DC10	10	10	22	72
	95DCL10	10	10	40	89
	95DCXL10	10	10	50	120
12,0	95DC12	12	12	26	83

→ Durchmesserbereich:
2,0 bis 12,0 mm

diameter range:
2,0 to 12,0 mm

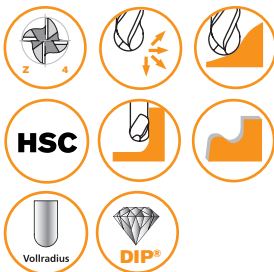

END MILL 4F

center cutting

91DC SCHAFTFRÄSER							
BESTELL-NUMMER ORDER NUMBER	D1 mm	D2 h6 mm	L2 mm	L1 mm	L3 mm	ER	mm
2,0	91DC02	2	3	6	40		
2,5	91DC025	2,5	3	7	40		
3,0	91DC03	3	3	10	40		
	91DCL03	3	3	18	60		
	91DCXL03	3	3	25	75		
4,0	91DC04	4	4	11	40		
	91DCL04	4	4	20	60		
	91DCXL04	4	4	32	75		
5,0	91DC05	5	5	13	50		
	91DCL05	5	5	25	62		
	91DCXL05	5	5	38	100		
6,0	91DC06	6	6	16	50		
	91DCL06	6	6	30	70		
	91DCXL06	6	6	40	100		
8,0	91DC08	8	8	19	63		
	91DCL08	8	8	35	79		
	91DCXL08	8	8	45	100		
10,0	91DC10	10	10	22	72		
	91DC1005	10	10	12	89		0,5
	91DC1010	10	10	12	89		1,0
	91DCF1005	10	10	12	89	40	0,5
	91DCF1005	10	10	12	89	50	0,5
	91DCF1010	10	10	12	89	40	1,0
	91DCF1010	10	10	12	89	50	1,0
	91DCL10	10	10	40	89		
	91DCXL10	10	10	50	120		
12,0	91DC12	12	12	26	83		
	91DC1205	12	12	16	100		0,5
	91DC1210	12	12	16	100		1,0
	91DC1220	12	12	16	100		2,0
	91DCL12	12	12	50	100		
	91DCXL12	12	12	60	150		
16,0	91DC16	16	16	32	92		
	91DC1605	16	16	20	125		0,5
	91DC1610	16	16	20	125		1,0
	91DC1620	16	16	20	125		2,0
	91DCL16	16	16	58	125		
	91DCXL16	16	16	75	150		
20,0	91DC20	20	20	38	104		
	91DC2010	20	20	24	125		1,0
	91DC2015	20	20	24	125		1,5
	91DC2020	20	20	24	125		2,0
	91DC2030	20	20	24	125		3,0
	91DCL20	20	20	60	125		
	91DCXL20	20	20	75	150		

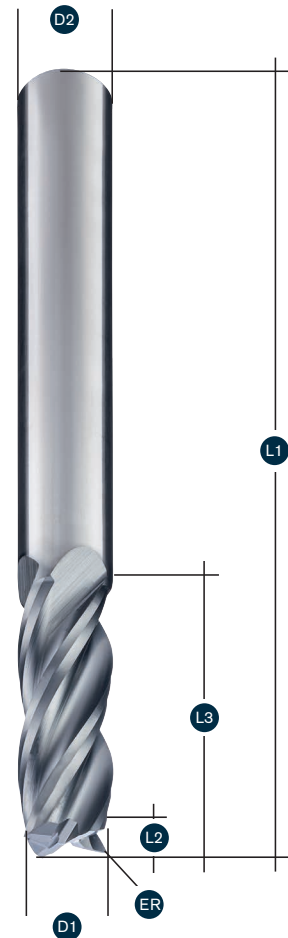

GRAPHIT LINE

→ Durchmesserbereich:
2,0 bis 20,0 mm

diameter range:
2,0 to 20,0 mm





P100RG PKD-KUGELFRÄSER

BESTELL-NUMMER ORDER NUMBER	D1 mm	D2 h6 mm	L2 mm	L1 mm	L3 mm
3,0 P100RGECO03-9	3	6	2,5	70	9
P100RGECO03-15	3	6	2,5	70	15
P100RGECO03-21	3	6	2,5	70	21
4,0 P100RGECO04-12	4	6	2,5	70	12
P100RGECO04-20	4	6	2,5	70	20
P100RGECO04-28	4	6	2,5	70	28
5,0 P100RGECO05-15	5	6	3	70	15
P100RGECO05-25	5	6	3	70	25
P100RGECO05-35	5	6	3	70	35
6,0 P100RGECO06-18	6	6	6	100	18
P100RGECO06-30	6	6	6	100	30
P100RGECO06-35	6	6	6	100	35
8,0 P100RGECO08-24	8	8	7	100	24
P100RGECO08-40	8	8	7	100	40
10,0 P100RGECO10-30	10	10	8	100	30
P100RGECO10-50	10	10	8	100	50
12,0 P100RGECO12-36	12	12	9	100	36
P100RGECO12-60	12	12	9	100	60

→ Durchmesserbereich:
3,0 bis 12,0 mm

diameter range:
3,0 to 12,0 mm



PCD-TORIC END MILL 2F

straight - right cutting

P100G PKD-TORUSFRÄSER							
BESTELL-NUMMER ORDER NUMBER	D1 mm	D2 h6 mm	L2 mm	L1 mm	L3 mm	ER	
3,0	P100GECO03-9-03	3	6	2,5	70	9	0,3
	P100GECO03-15-03	3	6	2,5	70	15	0,3
	P100GECO03-21-03	3	6	2,5	70	21	0,3
4,0	P100GECO04-12-03	4	6	2,5	70	12	0,3
	P100GECO04-20-03	4	6	2,5	70	20	0,3
	P100GECO04-28-03	4	6	2,5	70	28	0,3
5,0	P100GECO05-15-03	5	6	3	70	15	0,3
	P100GECO05-25-03	5	6	3	70	25	0,3
	P100GECO05-35-03	5	6	3	70	35	0,3
6,0	P100GECO06-18-03	6	6	6	100	18	0,3
	P100GECO06-30-03	6	6	6	100	30	0,3
	P100GECO06-42-03	6	6	6	100	42	0,3
	P100GECO06-18-05	6	6	6	100	18	0,5
	P100GECO06-30-05	6	6	6	100	30	0,5
	P100GECO06-42-05	6	6	6	100	42	0,5
	P100GECO06-18-10	6	6	6	100	18	1,0
	P100GECO06-30-10	6	6	6	100	30	1,0
	P100GECO06-42-10	6	6	6	100	42	1,0
8,0	P100GECO08-24-03	8	8	7	100	24	0,3
	P100GECO08-40-03	8	8	7	100	40	0,3
	P100GECO08-24-05	8	8	7	100	24	0,5
	P100GECO08-40-05	8	8	7	100	40	0,5
	P100GECO08-24-10	8	8	7	100	24	1,0
	P100GECO08-40-10	8	8	7	100	40	1,0
10,0	P100GECO10-30-05	10	10	8	100	30	0,5
	P100GECO10-50-05	10	10	8	100	50	0,5
	P100GECO10-30-10	10	10	8	100	30	1,0
	P100GECO10-50-10	10	10	8	100	50	1,0
	P100GECO10-30-15	10	10	8	100	30	1,5
	P100GECO10-50-15	10	10	8	100	50	1,5
12,0	P100GECO12-36-05	12	12	9	100	36	0,5
	P100GECO12-60-05	12	12	9	100	60	0,5
	P100GECO12-36-10	12	12	9	100	36	1,0
	P100GECO12-60-10	12	12	9	100	60	1,0
	P100GECO12-36-15	12	12	9	100	36	1,5
	P100GECO12-60-15	12	12	9	100	60	1,5

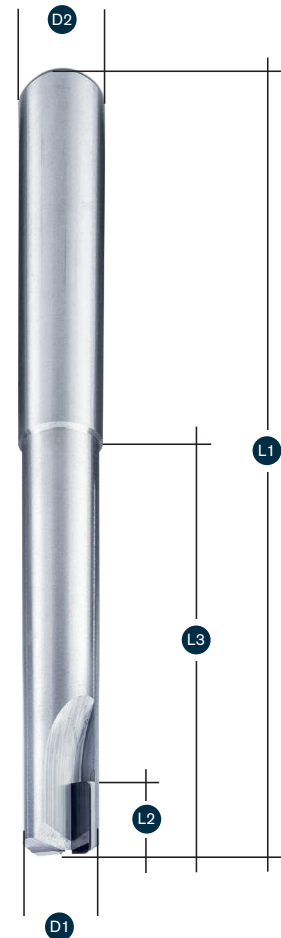

GRAPHIT LINE

→ Durchmesserbereich:
3,0 bis 12,0 mm
diameter range:
3,0 to 12,0 mm

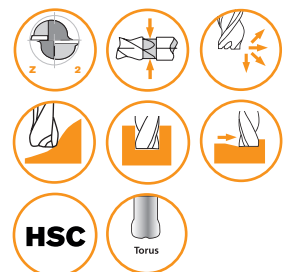

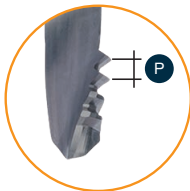
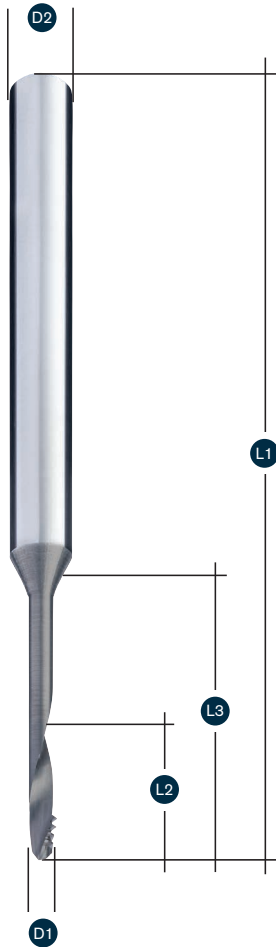

→ Nennmaß:
M 2 bis M 12

nominal dimension:
M 2 to M 12

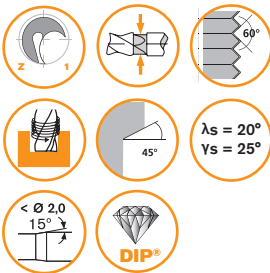

110GF DIP® GEWINDEFÄRÄSER

BESTELL-NUMMER ORDER NUMBER	M	D1 mm	D2 h6 mm	L2 mm	L1 mm	L3 mm	E-Maß	P
110GF-M2-DIP	M 2	0,82	3	4	50	8	0,29	0,4
110GF-M2,5-DIP	M 2,5	1,1	3	6	50	10	0,32	0,45
110GF-M3-DIP	M 3	1,42	6	10	60	15	0,37	0,5
110GF-M4-DIP	M 4	1,74	6	15	75	20	0,52	0,7
110GF-M5-DIP	M 5	2,5	6	18	75	25	0,57	0,8
110GF-M6-DIP	M 6	3,0	8	20	75	30	0,75	1,0
110GF-M8-DIP	M 8	4,2	10	25	100	35	0,9	1,25
110GF-M10-DIP	M 10	5,39	12	30	100	40	1,1	1,5
110GF-M12-DIP	M 12	6,67	12	30	100	40	1,25	1,75

TAP DRILL
for CFK, Graphite and mixed materials

KD201 DIP® SPIRALBOHRER						
BESTELL-NUMMER ORDER NUMBER	M	D1 mm	D2 h6 mm	L2 mm	L1 mm	
0,5		0,5	3	2,5	50	
0,75		0,75	3	4	50	
0,8		0,8	3	5	50	
1,0		1,0	3	7	50	
1,2		1,2	3	8	50	
1,5		1,5	3	10	50	
1,6	M 2	1,6	3	11	50	
1,8		1,8	3	12	50	
2,0		2,0	3	14	50	
2,05	M 2,5	2,05	3	14	50	
2,5	M 3	2,5	3	16	50	
2,8		2,8	3	16	50	
3,0		3,0	3	18	50	
3,3	M 4	3,3	4	20	60	
3,5		3,5	4	20	60	
3,7		3,7	4	20	60	
4,0		4,0	4	24	60	
4,2	M 5	4,2	5	24	62	
4,5		4,5	5	24	62	
4,65		4,65	5	25	62	
5,0	M 6	5,0	5	28	62	
5,5		5,5	6	28	75	
5,55		5,55	6	28	75	
6,0		6,0	6	30	75	
6,8	M 8	6,8	8	32	75	
7,0		7,0	8	32	75	
7,45		7,45	8	32	75	
7,5		7,5	8	35	100	
8,0		8,0	8	40	100	
8,5	M 10	8,5	10	45	100	
9,0		9,0	10	45	100	
9,35		9,35	10	45	100	
9,5		9,5	10	45	100	
10,0		10,0	10	50	100	
10,2	M 12	10,2	12	60	125	
10,5		10,5	12	60	125	
11,0		11,0	12	60	125	
11,2		11,2	12	60	125	
11,5		11,5	12	60	125	
12,0		12,0	12	60	125	

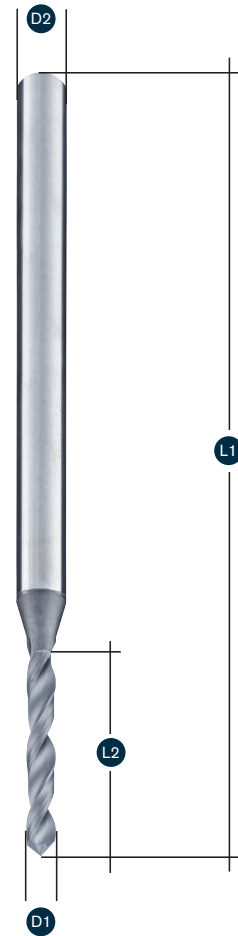

GRAPHIT LINE

→ Durchmesserbereich:
0,5 bis 12,0 mm

diameter range:
0,5 to 12,0 mm

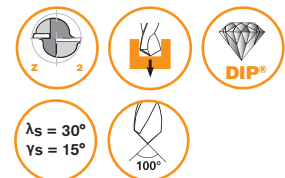

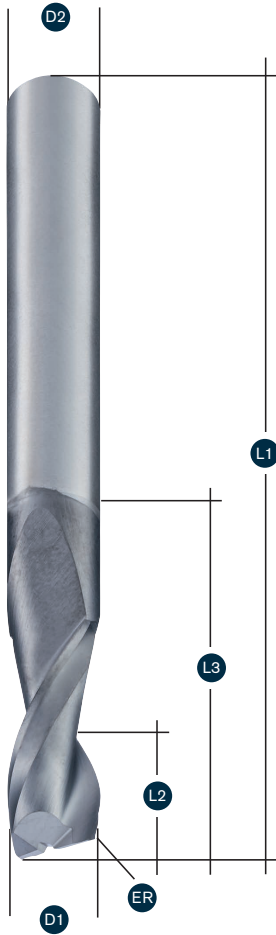

→ Durchmesserbereich:
1,0 bis 12,0 mm

diameter range:
1,0 to 12,0 mm



93DCECO TORUSFRÄSER							
BESTELL-NUMMER ORDER NUMBER	D1 mm	D2 h6 mm	L2 mm	L1 mm	L3 mm	ER	
1,0	93DCECO01-10	1	3	1,2	60	10	0,1
	93DCECO01-1002	1	3	1,2	60	10	0,2
	93DCECO01-15	1	3	1,2	60	15	0,1
	93DCECO01-1502	1	3	1,2	60	15	0,2
	93DCECO01-20	1	3	1,2	60	20	0,1
	93DCECO01-2002	1	3	1,2	60	20	0,2
	93DCECO01-25	1	3	1,2	60	25	0,1
1,2	93DCECO012-6	1,2	3	1,5	60	6	0,1
	93DCECO012-12	1,2	3	1,5	60	12	0,2
	93DCECO012-18	1,2	3	1,5	60	18	0,1
	93DCECO012-20	1,2	3	1,5	60	20	0,2
	93DCECO012-24	1,2	3	1,5	60	24	0,1
1,5	93DCECO015-10	1,5	3	1,7	60	10	0,1
	93DCECO015-1015	1,5	3	1,7	60	10	0,15
	93DCECO015-15	1,5	3	1,7	60	15	0,1
	93DCECO015-1515	1,5	3	1,7	60	15	0,15
	93DCECO015-1520	1,5	3	1,7	60	15	0,2
	93DCECO015-20	1,5	3	1,7	60	20	0,1
	93DCECO015-2020	1,5	3	1,7	60	20	0,2
	93DCECO015-25	1,5	3	1,7	60	25	0,1
	93DCECO015-2520	1,5	3	1,7	60	25	0,2
2,0	93DCECO02-10	2	3	4	60	10	0,2
	93DCECO02-15	2	3	4	60	15	0,2
	93DCECO02-1505	2	3	4	60	15	0,5
	93DCECO02-20	2	3	4	60	20	0,2
	93DCECO02-2005	2	3	4	60	20	0,5
	93DCECO02-25	2	3	4	60	25	0,2
	93DCECO02-30	2	3	4	60	30	0,2
3,0	93DCECO03-15	3	3	6	60	15	0,25
	93DCECO03-1505	3	3	6	60	15	0,5
	93DCECO03-20	3	3	6	60	20	0,25
	93DCECO03-2003	3	3	6	60	20	0,3
	93DCECO03-25	3	3	6	60	25	0,25
	93DCECO03-2505	3	3	6	60	25	0,5
	93DCECO03-30	3	3	6	60	30	0,25
4,0	93DCECO04-2005	4	4	4	60	20	0,5
	93DCECO04-3005	4	4	4	60	30	0,5
	93DCECO0404-25	4	4	6	60	25	0,4
	93DCECO0405-25	4	4	6	60	25	0,5
5,0	93DCECO05-20	5	5	7,5	62	20	0,5
	93DCECO05-25	5	5	7,5	62	25	0,5
	93DCECO05-30	5	5	7,5	62	30	0,5
	93DCECO05-40	5	5	7,5	62	40	0,5
	93DCECOL05-40	5	5	7,5	75	40	0,5

TORIC-END MILL 2F

center cutting

93DCECO TORUSFRÄSER

	BESTELL-NUMMER ORDER NUMBER	D1 mm	D2 h6 mm	L2 mm	L1 mm	L3 mm	ER mm
6,0	93DCECO0605-25	6	6	10	75	25	0,5
	93DCECO0610-25	6	6	10	75	25	1,0
	93DCECO0605-35	6	6	10	75	35	0,5
	93DCECO0610-35	6	6	10	75	35	1,0
	93DCECO0605-45	6	6	10	75	45	0,5
	93DCECO0605-60	6	6	10	100	60	0,5
	93DCECO0605-70	6	6	10	100	70	0,5
8,0	93DCECO0805-30	8	8	12	75	30	0,5
	93DCECO0810-30	8	8	12	75	30	1,0
	93DCECO0805-35	8	8	12	75	35	0,5
	93DCECO0805-40	8	8	12	75	40	0,5
	93DCECO0810-40	8	8	12	75	40	1,0
10,0	93DCECO1005-35	10	10	15	72	35	0,5
	93DCECO1010-35	10	10	15	72	35	1,0
12,0	93DCECO1205-35	12	12	15	83	35	0,5
	93DCECO1210-35	12	12	15	83	35	1,0
	93DCECO1210-40	12	12	15	83	40	1,0

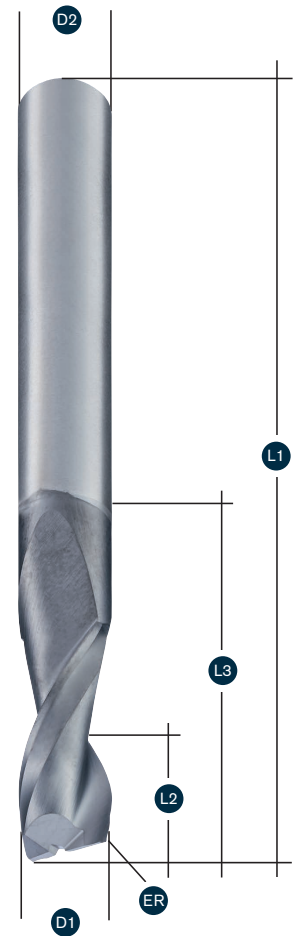

GRAPHIT LINE

→ Durchmesserbereich:
1,0 bis 12,0 mm

diameter range:
1,0 to 12,0 mm



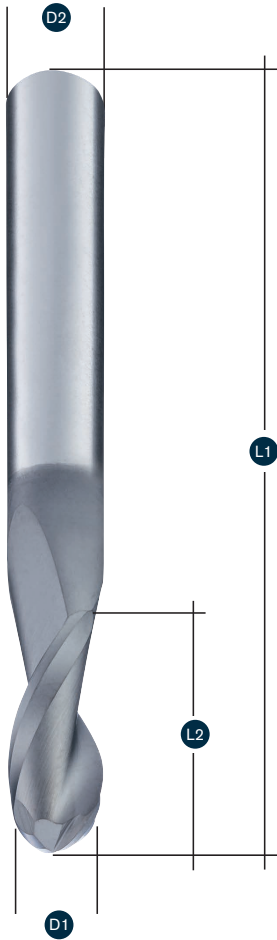

97DCECO MINI-TORUSFRÄSER

BESTELL-NUMMER ORDER NUMBER	D1 mm	D2 h6 mm	L2 mm	L1 mm	L3 mm
1,0 97DCECO01-10	1	3	1,25	60	10
97DCECO01-12	1	3	1,25	60	12
97DCECO01-15	1	3	1,25	60	15
97DCECO01-20	1	3	1,25	60	20
97DCECO01-25	1	3	1,25	60	25
97DCECO01-30	1	3	1,25	60	30
1,2 97DCECO012-6	1,2	3	1,5	60	6
97DCECO012-12	1,2	3	1,5	60	12
97DCECO012-18	1,2	3	1,5	60	18
97DCECO012-24	1,2	3	1,5	60	24
1,5 97DCECO015-10	1,5	3	2	60	10
97DCECO015-15	1,5	3	2	60	15
97DCECO015-20	1,5	3	2	60	20
97DCECO015-25	1,5	3	2	60	25
2,0 97DCECO02-15	2	3	2,5	60	15
97DCECO02-20	2	3	2,5	60	20
97DCECO02-25	2	3	2,5	60	25
97DCECO02-30	2	3	2,5	60	30
3,0 97DCECO03-15	3	3	4	60	15
97DCECO03-20	3	3	4	60	20
97DCECO03-25	3	3	4	60	25
97DCECO03-30	3	3	4	60	30
4,0 97DCECO04-16	4	4	6	60	16
97DCECO04-25	4	4	6	60	25
97DCECO04-30	4	4	6	60	30
97DCECO04-40	4	4	6	60	40
5,0 97DCECO05-25	5	5	7,5	75	25
97DCECO05-30	5	5	7,5	75	30
97DCECO05-40	5	5	7,5	75	40
6,0 97DCECO06-30	6	6	10	75	30
97DCECO06-35	6	6	10	75	35
97DCECO06-40	6	6	10	75	40
97DCECO06-45	6	6	10	75	45
8,0 97DCECO08-30	8	8	12	75	30
97DCECO08-35	8	8	12	75	35
97DCECO08-40	8	8	12	75	40
10,0 97DCECO10-30	10	10	15	72	30
97DCECO10-35	10	10	15	72	35
97DCECO10-40	10	10	15	72	40
12,0 97DCECO12-35	12	12	15	83	35
97DCECO12-40	12	12	15	83	40

→ Durchmesserbereich:
1,0 bis 12,0 mm

diameter range:
1,0 to 12,0 mm

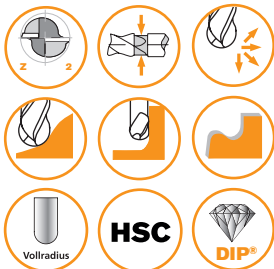



↓ Pic 4
Forschungs- und
Entwicklungsbesprechung

Research and development
meeting

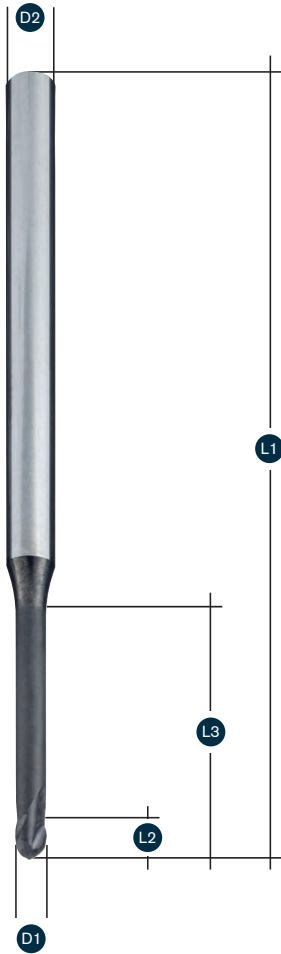

HM915ECO MINI-KUGELFRÄSER (KOPFRADIUS $R = 0,5 \times D1$)

BESTELL-NUMMER ORDER NUMBER	D1 mm	D2 h6 mm	L2 mm	L1 mm	L3 mm
0,2 HM915ECO002-1-DIP	0,2	3	0,2	50	1
0,3 HM915ECO003-2-DIP	0,3	3	0,4	50	2
HM915ECO003-3-DIP	0,3	3	0,4	50	3
0,4 HM915ECO004-2-DIP	0,4	3	0,4	50	2
HM915ECO004-3-DIP	0,4	3	0,4	50	3
HM915ECO004-4-DIP	0,4	3	0,4	50	4
HM915ECO004-6-DIP	0,4	3	0,4	50	6
HM915ECO004-8-DIP	0,4	3	0,4	50	8
0,5 HM915ECO005-3-DIP	0,5	3	0,5	50	3
HM915ECO005-4-DIP	0,5	3	0,5	50	4
HM915ECO005-5-DIP	0,5	3	0,5	50	5
HM915ECO005-6-DIP	0,5	3	0,5	50	6
HM915ECO005-8-DIP	0,5	3	0,5	50	8
HM915ECO005-10-DIP	0,5	3	0,5	50	10
0,6 HM915ECO006-3-DIP	0,6	3	0,6	50	3
HM915ECO006-5-DIP	0,6	3	0,6	50	5
HM915ECO006-6-DIP	0,6	3	0,6	50	6
HM915ECO006-8-DIP	0,6	3	0,6	50	8
HM915ECO006-10-DIP	0,6	3	0,6	50	10
HM915ECO006-12-DIP	0,6	3	0,6	50	12
0,8 HM915ECO008-8-DIP	0,8	3	0,8	50	8
HM915ECO008-4-DIP	0,8	3	0,8	50	4
HM915ECO008-10-DIP	0,8	3	0,8	50	10
HM915ECO008-12-DIP	0,8	3	0,8	50	12
HM915ECO008-16-DIP	0,8	3	0,8	50	16

→ Durchmesserbereich:
0,2 bis 0,8 mm

diameter range:
0,2 to 0,8 mm



MINI-TORIC-END MILL 2F

center cutting

HM905ECO MINI-TORUSFRÄSER							
	BESTELL-NUMMER ORDER NUMBER	D1 mm	D2 h6 mm	L2 mm	L1 mm	L3 mm	ER mm
0,2	HM905ECO002005-1-DIP	0,2	3	0,5	50	1	0,05
	HM905ECO002-1-DIP	0,2	3	0,5	50	1	0,02
0,4	HM905ECO004-2-DIP	0,4	3	0,5	50	2	0,05
	HM905ECO004-3-DIP	0,4	3	0,5	50	3	0,05
	HM905ECO004-4-DIP	0,4	3	0,5	50	4	0,05
	HM905ECO004-6-DIP	0,4	3	0,5	50	6	0,05
	HM905ECO004-8-DIP	0,4	3	0,5	50	8	0,05
	HM905ECO004-10-DIP	0,4	3	0,5	50	10	0,05
0,5	HM905ECO005-3-DIP	0,5	3	0,5	50	3	0,05
	HM905ECO005-4-DIP	0,5	3	0,5	50	4	0,05
	HM905ECO005-5-DIP	0,5	3	0,5	50	5	0,05
	HM905ECO005-6-DIP	0,5	3	0,5	50	6	0,05
	HM905ECO005-8-DIP	0,5	3	0,5	50	8	0,05
	HM905ECO005-10-DIP	0,5	3	0,5	50	10	0,05
0,6	HM905ECO006-3-DIP	0,6	3	0,6	50	3	0,05
	HM905ECO006-6006-DIP	0,6	3	0,6	50	6	0,06
	HM905ECO006-6-DIP	0,6	3	0,6	50	6	0,05
	HM905ECO006-8-DIP	0,6	3	0,6	50	8	0,05
	HM905ECO006-10-DIP	0,6	3	0,6	50	10	0,05
	HM905ECO006-12-DIP	0,6	3	0,6	50	12	0,05
0,8	HM905ECO008-4-DIP	0,8	3	1,2	50	4	0,05
	HM905ECO008-8-DIP	0,8	3	1,2	50	8	0,05
	HM905ECO008-10-DIP	0,8	3	1,2	50	10	0,05
	HM905ECO008-12-DIP	0,8	3	1,2	50	12	0,05
	HM905ECO008-16-DIP	0,8	3	1,2	50	16	0,05

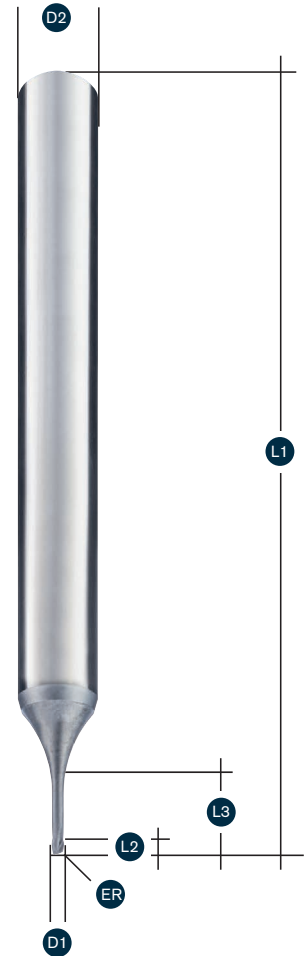

GRAPHIT LINE

→ Durchmesserbereich:
0,2 bis 0,8 mm

diameter range:
0,2 to 0,8 mm



ICONS



Anzahl der Zähne
number of cutting edges



Schafffräser
end mill



Freilegung
uncovering



Bearbeitungsrichtung Kugel
machining directions ball



Bearbeitungsrichtung Torus
machining directions torus



Bearbeitungsbeispiel Torusfräser
torus



Bearbeitungsbeispiel Schulterbearbeitung
shoulder processing



Bearbeitungsbeispiel 3D-Kopierfräser
3D-copying cutter processing



$\lambda_s = 20^\circ$
 $\gamma_s = 25^\circ$
Spanwinkel / Spiralwinkel
cutting angle / helix angle



Senkwinkel
counter sink angle



15°
Schaftwinkel
shank angle



Bearbeitungsrichtung Schafffräser
machining directions end mill



Bearbeitungsbeispiel Eckenbearbeitung
corner milling



Zirkularfräsen
circular machining



Bearbeitungsbeispiel 3D-Torusfräser
3D-ball processing



Torusfräser
toric end mill



Bearbeitungsbeispiel Einfahren über Rampe
ramp processing



Diamantbeschichtung
diamond coating



Freiformbearbeitung
3D-milling



Bearbeitungsbeispiel Profil
profiling



Bearbeitungsbeispiel Nuten
flute milling



Trennwerkzeug
cut off milling



Bohren
drilling



HSC **höchste Zerspanungsgeschwindigkeit**
high-speed-cutting



Eckenradius
corner radius



Spannutenkehle
flute spot



Gewinde-Flankenwinkel
thread mill



Bearbeitungsbeispiel
side milling



$< \varnothing 2,0$
 15°
Schaftwinkel
shank angle



Ecken Phase
corner chamfer



Spitzenwinkel
head angle



HPC **für höchstes Zerspanungsvolumen**
high performance milling



Vollradius
ball end mill

TOLERANZEN

	D1 mm	L1 mm	L2 mm	L3 mm	ER mm
D1					
<Ø3	0 -0,007	"0 +2"	"0 +0,4"	"0 +0,5"	+ -0,005*
Ø3,001 - Ø6	"0 -0,007"	"0 +2"	"0 +1"	"0 +1"	+ -0,005*
Ø6,001 - Ø10	"0 -0,008"	"0 +2"	"0 +1"	"0 +1"	+ -0,005*
Ø10,001 - Ø12	"0 -0,010"	"0 +2"	"0 +1"	"0 +1"	+ -0,005*

Ausgenommen S. 34 bis S. 45

*L1 ≤ 75 mm



Pic 5

Der „digitale Zwilling“ zur Konsolidierung der Qualität funktioniert über den angebrachten QR-Code.

Die Grafor®-Strategie von Hufschmied bietet uns sowohl hinsichtlich der Wirtschaftlichkeit wie auch der Prozesssicherheit eindeutige Vorteile. Wir arbeiten im vollautomatisierten 24/7-Betrieb und können die geforderten Fertigungstoleranzen von 0,010 mm prozesssicher gewährleisten.



Massimo Lolli, Vice President bei VETIMEC Soc. Coop.,
Bologna, Italien.

ERFOLG DURCH KUNDENNÄHE

Kundennähe ist die Voraussetzung für eine optimierte Zusammenarbeit.
Wir begleiten Ihren gesamten Produktionsprozess, von der Angebotsabgabe,
dem ersten Versuch, dem ersten Muster bis hin zur Serienproduktion.

Für weitere Details kontaktieren Sie uns bitte:

Tel.. +49 8234 9664-0

info@hufschmied.net

Auch andere Längen und Durchmesser sind möglich.

SUCCESS THROUGH PROXIMITY TO CUSTOMERS

*Proximity to customers is the condition for an op-
timized collaboration.
We accompany your whole production process, from submitting an offer,
the first trial, the first pattern to the series production.*

For more details please contact us:

Tel. +49 8234 9664-0

info@hufschmied.net

Other lengths and diameters are also available.



HUFSCHMIED
direct contact

HUFSCHMIED
ZERSpanUNGSSYSTEME GMBH

Edisonstraße 11 d

D-86399 Bobingen

Tel.: +49 82 34-96 64 0

Fax: +49 82 34-96 64 99

info@hufschmied.net