

UNIVERSAL-LINE

UNIVERSELL EINSETZBARE
FRÄSWERKZEUGE FÜR
THERMO-, DUROPLASTE
UND ELASTOMERE

*ALL-PURPOSE MILLING
TOOLS FOR
THERMOPLASTICS,
CURABLE PLASTICS AND
ELASTOMERS*



POM
POM

PA
PA

PE
PE

PP
PP

PVC
PVC

ABS
ABS

PS
PS

PUR
PUR

Gummi
Rubber

Latex
Latex

HUFSCHMIED
ZERSpanungSSYSTEME

UNIVERSAL-LINE

UNIVERSAL-LINE

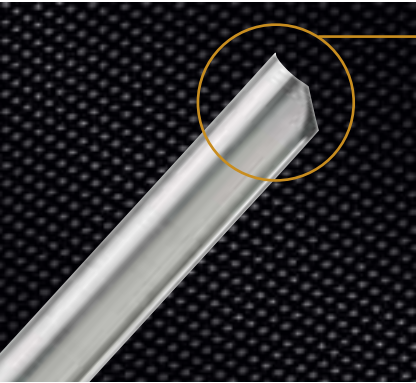

FRÄSER MIT EINER SCHNEIDE

MILLS WITH 1 FLUTE

Sie sind für Werkstoffkombinationen aus harten, weichen und gering verstärkten Kunststoffen ausgelegt. Sie erbringen in mittleren bis hohen Schnittgeschwindigkeitsbereichen hervorragende Ergebnisse.

They are designed for material combinations of strong, weak and slight intensified synthetics. They work in mid and high range cutting speeds and have the best results.

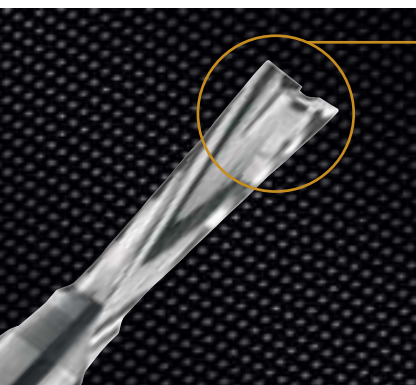

FRÄSER MIT ZWEI SCHNEIDEN

MILLS WITH TWO FLUTES

Sie werden bei der Kunststoffzerspanung im niederen bis mittleren Schnittgeschwindigkeitsbereich eingesetzt. Werkzeuge mit einer Spirale im Winkel von 45 Grad wurden für die Zerspanung von leder- oder textilkaschierten Bauteilen entwickelt.

They work in synthetic milling in low and mid-range cutting speeds. Tools with a helix in the angle of 45 ° were developed for the milling of leather- or textile-clad components.

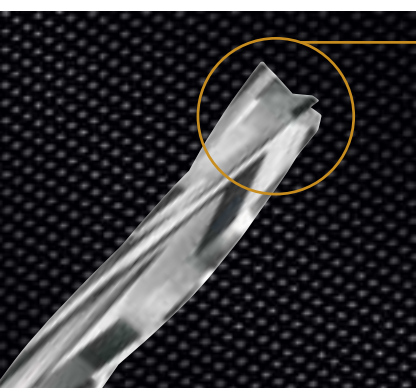

FRÄSER MIT DREI SCHNEIDEN

MILLS WITH THREE FLUTES

Diese Werkzeuge werden für Gummi und für Kombinationen aus weichen und schmierenden Werkstoffen mit Werkstoffen, die einen mittleren bis hohen Fasergehalt aufweisen, eingesetzt. Diese können im Verhältnis von bis zu 50:50 gemischt sein.

These tools should be used for rubber and for combinations of soft and greasing materials together with materials which have a mid and high percentage of fiber. These can be mixed in the proportion 50:50.

UNIVERSAL-LINE



WIR FERTIGEN AUCH
linksschneidige Werkzeuge
auf Anfrage

WE ALSO MANUFACTURE
left hand cutting tools
on demand

140

UNIVERSAL-Line-Fräser Z1 SL
rechtsdrall - linksschneidend

140

UNIVERSAL-Line-end mill 1F SL
right helix - left cutting

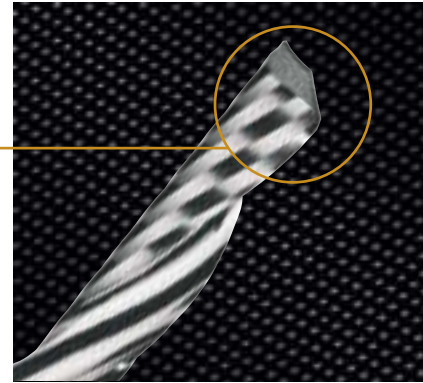

141

UNIVERSAL-Line-Fräser Z1 ZL
linksdrall - linksschneidend

141

UNIVERSAL-Line-end mill 1F ZL
left helix - left cutting

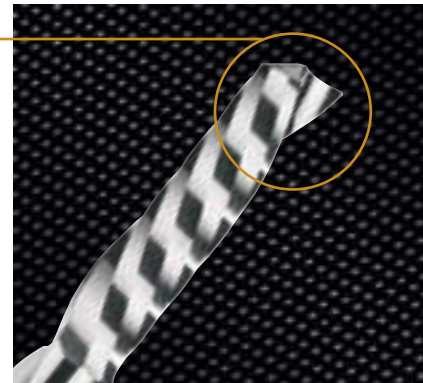

142

UNIVERSAL-Line-Fräser Z1 GL
gerade - linksschneidend

142

UNIVERSAL-Line-end mill 1F GL
straight - left cutting

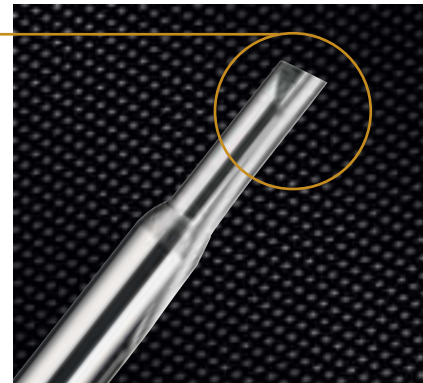

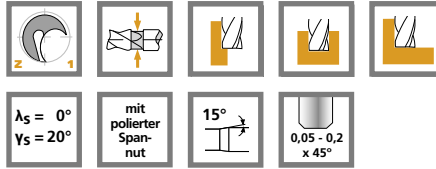
 $\lambda_s = 0^\circ$
 $\gamma_s = 20^\circ$
mit
polierter
Span-
nut

15°

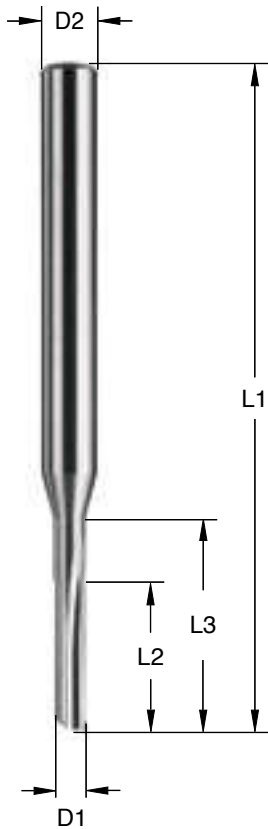
0,05 - 0,2
x 45°

Durchmesserbereich:
1,0 bis 20,0 mm
diameter range:
1,0 to 20,0 mm

Mögliche Beschichtungen:
TLX - Standard
ALX - auf Anfrage
possible coatings:
TLX - Standard
ALX - on demand

	BESTELL-NUMMER ORDER NUMBER	D1 mm / inch	D2 h6 mm / inch	L2 mm	L1 +2 mm	L3 mm	ER mm
1,0	132KK010	1	3	2	50		
	132010030	1	3	5	50		
2,0	112K020020	2	2	6	50		
	112020020	2	2	10	40		
	112H020020	2	2	12	60		
	112L020020	2	2	14	75		
	132KK020	2	3	3	50		
	132K020030	2	3	8	40		
	132020030	2	3	10	60		
	132L020030	2	3	10	75		
3,0	112KK030	3	3	4	50		
	112K030030	3	3	8	50		
	112030030	3	3	12	40		
	112H030030	3	3	15	60		
	112L030030	3	3	18	75		
	132K030060	3	6	8	50		
	132030060	3	6	18	60		
	132L030060	3	6	18	75		
3,17 / 1/8"	1120317317	3,17 / 1/8"	3,17 / 1/8"	12	38		
	112L0317317	3,17 / 1/8"	3,17 / 1/8"	18	75		
4,0	112040040	4	4	15	40		
	112KK040	4	4	5	50		
	112K040040	4	4	12	50		
	112H040040	4	4	18	60		
	112L040040	4	4	20	75		
	132K040060	4	6	12	50		
	132040060	4	6	20	60		
	132L040060	4	6	20	75		
4,76 / 3/16"	1120476476	4,76 / 3/16"	4,76 / 3/16"	15	50		
	112L0476476	4,76 / 3/16"	4,76 / 3/16"	20	75		
5,0	112KK050	5	5	6	50		
	112050050	5	5	16	50		
	112H050050	5	5	20	60		
	112L050050	5	5	28	75		
	132K050060	5	6	16	50		
	132050060	5	6	28	60		
	132L050060	5	6	28	75		
	132L050080	5	8	20	95	30	
6,0	112KK060	6	6	7	50		
	112K060060	6	6	16	50		
	112060060	6	6	20	60		
	112L060060	6	6	35	75		
	132K060080	6	8	18	63		
	132060080	6	8	35	75		
	132L060080	6	8	20	95	30	
6,35 / 1/4"	1120635635	6,35 / 1/4"	6,35 / 1/4"	20	63		
	112L0635635	6,35 / 1/4"	6,35 / 1/4"	35	75		

Die Preise entnehmen Sie bitte unserer aktuellen Preisliste.
Please take prices out of our actual price list.

Bei der Bestellung bitte die Bestellnummer angeben: Best.Nr.: z.B. 112H080080 und wenn gewünscht Beschichtung: z.B. TLX.

Please indicate order number: e.g. 132K060080 and if wanted COATING: e.g. TLX.

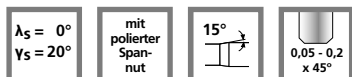

BESTELL-NUMMER ORDER NUMBER		D1 mm / inch	D2 h6 mm / inch	L2 mm	L1 +2 mm	L3 mm	ER mm
7,93 / 5/16"	1120793793	7,93 / 5/16"	7,93 / 5/16"	22	63		
	112L0793793	7,93 / 5/16"	7,93 / 5/16"	35	75		
8,0	112KK080	8	8	9	50		
	112K080080	8	8	18	50		
	112080080	8	8	22	63		
	112H080080	8	8	30	75		
	112L080080	8	8	40	100		
	132080100	8	10	40	100		
9,52 / 3/8"	1120952952	9,52 / 3/8"	9,52 / 3/8"	25	75		
	112L0952952	9,52 / 3/8"	9,52 / 3/8"	40	100		
10,0	112100100	10	10	25	72		
	112L100100	10	10	55	100		
12,0	112120120	12	12	30	83		
12,7 / 1/2"	112127127	12,7 / 1/2"	12,7 / 1/2"	30	75		
14,0	112140140	14	14	30	83		
16,0	112160160	16	16	35	92		
18,0	112180180	18	18	35	92		
20,0	112200200	20	20	40	104		

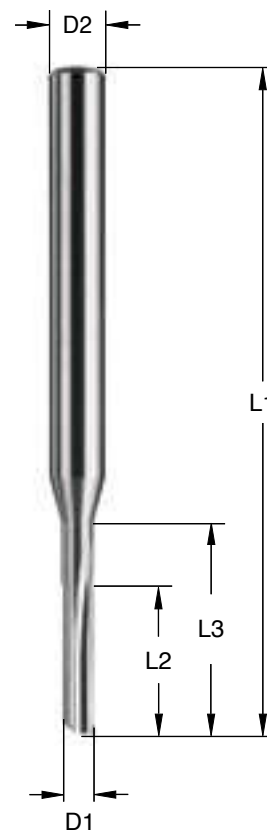

Durchmesserbereich:
1,0 bis 20,0 mm
diameter range:
1,0 to 20,0 mm

Mögliche Beschichtungen:
TLX - Standard
ALX - auf Anfrage
possible coatings:
TLX - Standard
ALX - on demand

Die Preise entnehmen Sie bitte unserer aktuellen Preisliste.
Please take prices out of our actual price list.

Bei der Bestellung bitte die Bestellnummer angeben: Best.Nr.: z.B. 112H080080 und wenn gewünscht Beschichtung: z.B. TLX.
Please indicate order number: e.g. 112L080080 and if wanted COATING: e.g. TLX.

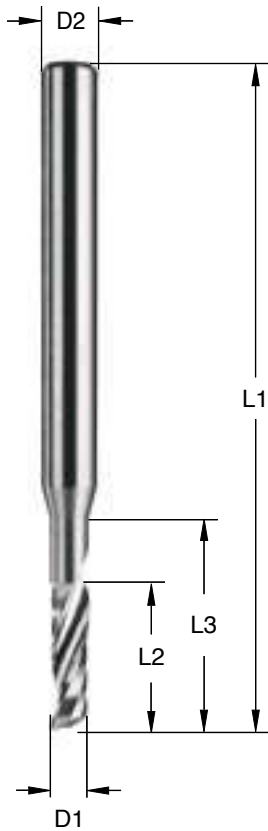
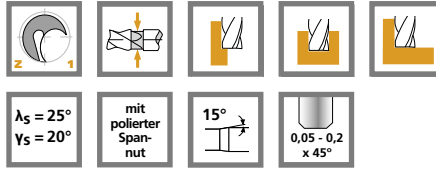

Durchmesserbereich:
1,0 bis 20,0 mm
diameter range:
1,0 to 20,0 mm

Mögliche Beschichtungen:
TLX - Standard
ALX - auf Anfrage
possible coatings:
TLX - Standard
ALX - on demand

	BESTELL-NUMMER ORDER NUMBER	D1 mm / inch	D2 h6 mm / inch	L2 mm	L1 +2 mm	L3 mm	ER mm
1,0	130KK010	1	3	2	50		
	130010030	1	3	5	50		
2,0	110K020020	2	2	6	50		
	110020020	2	2	10	40		
	110H020020	2	2	12	60		
	110L020020	2	2	14	75		
	130KK020	2	3	3	50		
	130K020030	2	3	8	40		
	130K020-025	2	3	6	40		0,25
	130020030	2	3	10	60		
	130020-025	2	3	10	60		0,25
	130L020030	2	3	10	75		
3,0	110KK030	3	3	4	50		
	110K030030	3	3	8	50		
	110030030	3	3	12	40		
	110030-025	3	3	12	40		0,25
	110H030030	3	3	15	60		
	110L030030	3	3	18	75		
	130K030060	3	6	8	50		
	130K030-025	3	6	8	50		0,25
	130030060	3	6	18	60		
	130030-025	3	6	18	60		0,25
	130L030060	3	6	18	75		
	3,17 / 1/8"	1100317317	3,17 / 1/8"	3,17 / 1/8"	12	38	
110L0317317		3,17 / 1/8"	3,17 / 1/8"	18	75		
4,0	110KK040	4	4	5	50		
	110K040040	4	4	12	50		
	110040040	4	4	15	40		
	110040-025	4	4	15	40		0,25
	110H040040	4	4	18	60		
	110L040040	4	4	20	75		
	130K040060	4	6	12	50		
	130K040-050	4	6	12	50		0,5
	130040060	4	6	20	60		
	130040-050	4	6	20	60		0,5
4,76 / 3/16"	1100476476	4,76 / 3/16"	4,76 / 3/16"	15	50		
	110L0476476	4,76 / 3/16"	4,76 / 3/16"	20	75		
5,0	110KK050	5	5	6	50		
	110050050	5	5	16	50		
	110050-050	5	5	16	50		0,5
	110H050050	5	5	20	60		
	110L050050	5	5	28	75		
	130K050060	5	6	16	50		
	130K050-050	5	6	16	50		0,5
	130050060	5	6	28	60		
	130L050060	5	6	28	75		
	130L050080	5	8	20	95	30	

Die Preise entnehmen Sie bitte unserer aktuellen Preisliste.
Please take prices out of our actual price list.

Bei der Bestellung bitte die Bestellnummer angeben: Best.Nr.: z.B. 130K050060 und wenn gewünscht Beschichtung: z.B. TLX.

Please indicate order number: e.g. 1130L050080 and if wanted COATING: e.g. TLX.

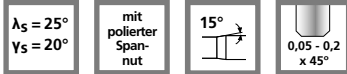

BESTELL-NUMMER ORDER NUMBER		D1 mm / inch	D2 h6 mm / inch	L2 mm	L1 +2 mm	L3 mm	ER mm
6,0	110KK060	6	6	7	50		
	110K060060	6	6	16	50		
	110K060-050	6	6	16	50		0,5
	110060060	6	6	20	60		
	110060-050	6	6	20	60		0,5
	110L060060	6	6	35	75		
	130K060080	6	8	18	63		
	130060080	6	8	35	75		
	130L060080	6	8	20	95	30	
6,35 / 1/4"	1100635635	6,35 / 1/4"	6,35 / 1/4"	20	63		
	110L0635635	6,35 / 1/4"	6,35 / 1/4"	35	75		
7,93 / 5/16"	1100793793	7,93 / 5/16"	7,93 / 5/16"	22	63		
	110L0793793	7,93 / 5/16"	7,93 / 5/16"	40	100		
8,0	110KK080	8	8	9	50		
	110K080080	8	8	18	50		
	110K080-050	8	8	18	50		0,5
	110080080	8	8	22	63		
	110080-050	8	8	22	63		0,5
	110H080080	8	8	30	75		
	110L080080	8	8	40	100		
	130080100	8	10	40	100		
9,52 / 3/8"	1100952952	9,52 / 3/8"	9,52 / 3/8"	25	75		
	110L0952952	9,52 / 3/8"	9,52 / 3/8"	55	100		
10,0	110100100	10	10	25	72		
	110L100100	10	10	55	100		
	110FL100100	10	10	30	150	70	
12,0	110120120	12	12	30	83		
	110FL120120	12	12	40	150	80	
12,7 / 1/2"	110127127	12,7 / 1/2"	12,7 / 1/2"	30	75		
14,0	110140140	14	14	30	83		
16,0	110160160	16	16	35	92		
	110FL160160	16	16	50	150	100	
18,0	110180180	18	18	35	92		
20,0	110200200	20	20	40	104		
	110FL200200	20	20	50	150	100	

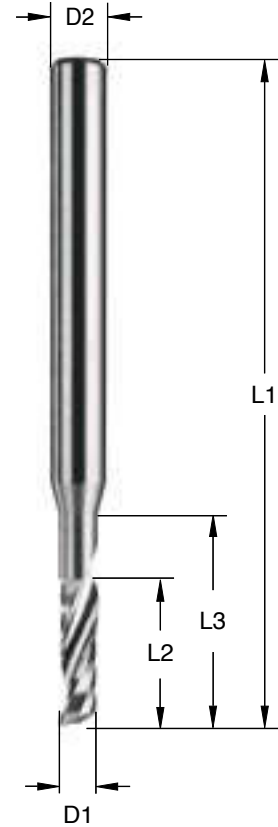

Durchmesserbereich:
1,0 bis 20,0 mm
diameter range:
1,0 to 20,0 mm

Mögliche Beschichtungen:
TLX - Standard
ALX - auf Anfrage
possible coatings:
TLX - Standard
ALX - on demand

Die Preise entnehmen Sie bitte unserer aktuellen Preisliste.
Please take prices out of our actual price list.

Bei der Bestellung bitte die Bestellnummer angeben: Best.Nr.: z.B. 110FL160160 und wenn gewünscht Beschichtung: z.B. TLX.
Please indicate order number: e.g. 110FL200200 and if wanted COATING: e.g. TLX.

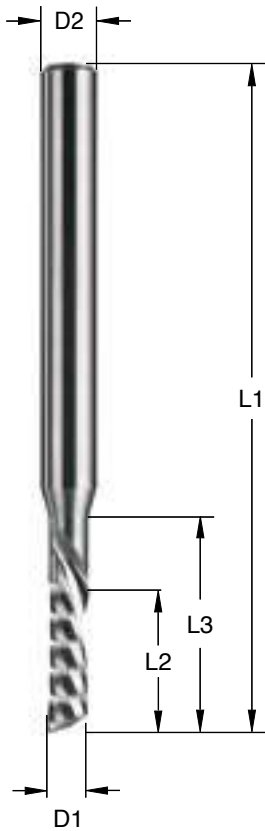
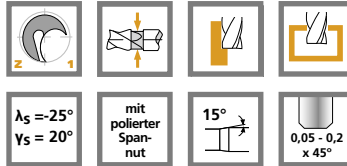

Durchmesserbereich:
1,0 bis 20,0 mm
diameter range:
1,0 to 20,0 mm

Mögliche Beschichtungen:
TLX - Standard
ALX - auf Anfrage
possible coatings:
TLX - Standard
ALX - on demand

	BESTELL-NUMMER ORDER NUMBER	D1 mm / inch	D2 h6 mm / inch	L2 mm	L1 +2 mm	L3 mm	ER mm
1,0	131KK010	1	3	2	50		
	131010030	1	3	5	50		
2,0	111K020020	2	2	6	50		
	111020020	2	2	10	40		
	111H020020	2	2	12	60		
	111L020020	2	2	14	75		
	131KK020	2	3	3	50		
	131K020030	2	3	8	40		
	131020030	2	3	10	60		
	131L020030	2	3	10	75		
3,0	111KK030	3	3	4	50		
	111K030030	3	3	8	50		
	111030030	3	3	12	40		
	111H030030	3	3	15	60		
	111L030030	3	3	18	75		
	131K030060	3	6	8	50		
	131030060	3	6	18	60		
	131L030060	3	6	18	75		
3,17 / 1/8"	1110317317	3,17 / 1/8"	3,17 / 1/8"	12	38		
	111L0317317	3,17 / 1/8"	3,17 / 1/8"	18	75		
4,0	111KK040	4	4	5	50		
	111K040040	4	4	12	50		
	111040040	4	4	15	40		
	111H040040	4	4	18	60		
	111L040040	4	4	20	75		
	131K040060	4	6	12	50		
	131040060	4	6	20	60		
	131L040060	4	6	20	75		
4,76 / 3/16"	1110476476	4,76 / 3/16"	4,76 / 3/16"	15	50		
	111L0476476	4,76 / 3/16"	4,76 / 3/16"	20	75		
5,0	111KK050	5	5	6	50		
	111050050	5	5	16	50		
	111H050050	5	5	20	60		
	111L050050	5	5	28	75		
	131K050060	5	6	16	50		
	131050060	5	6	28	60		
	131L050060	5	6	28	75		
	131L050080	5	8	20	95	30	
6,0	111KK060	6	6	7	50		
	111K060060	6	6	16	50		
	111060060	6	6	20	60		
	111L060060	6	6	35	75		
	131K060080	6	8	18	63		
	131060080	6	8	35	75		
	131L060080	6	8	20	95	30	

Die Preise entnehmen Sie bitte unserer aktuellen Preisliste.
Please take prices out of our actual price list.

Bei der Bestellung bitte die Bestellnummer angeben: Best.Nr.: z.B. 131K050060 und wenn gewünscht Beschichtung: z.B. TLX.
Please indicate order number: e.g. 111L050050 and if wanted COATING: e.g. TLX.

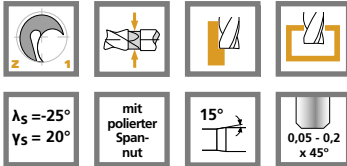

BESTELL-NUMMER ORDER NUMBER		D1 mm / inch	D2 h6 mm / inch	L2 mm	L1 +2 mm	L3 mm	ER mm
6,35 / 1/4"	1110635635	6,35 / 1/4"	6,35 / 1/4"	20	63		
	111L0635635	6,35 / 1/4"	6,35 / 1/4"	35	75		
7,93 / 5/16"	1110793793	7,93 / 5/16"	7,93 / 5/16"	22	63		
	111L0793793	7,93 / 5/16"	7,93 / 5/16"	40	100		
8,0	111KK080	8	8	9	50		
	111K080080	8	8	18	50		
	111080080	8	8	22	63		
	111H080080	8	8	30	75		
	111L080080	8	8	40	100		
	131080100	8	10	40	100		
9,52 / 3/8"	1110952952	9,52 / 3/8"	9,52 / 3/8"	25	75		
	111L0952952	9,52 / 3/8"	9,52 / 3/8"	40	100		
10,0	111100100	10	10	25	72		
	111L100100	10	10	55	100		
12,0	111120120	12	12	30	83		
12,7 / 1/2"	111127127	12,7 / 1/2"	12,7 / 1/2"	30	76		
14,0	111140140	14	14	30	83		
16,0	111160160	16	16	35	92		
18,0	111180180	18	18	35	92		
20,0	111200200	20	20	40	104		

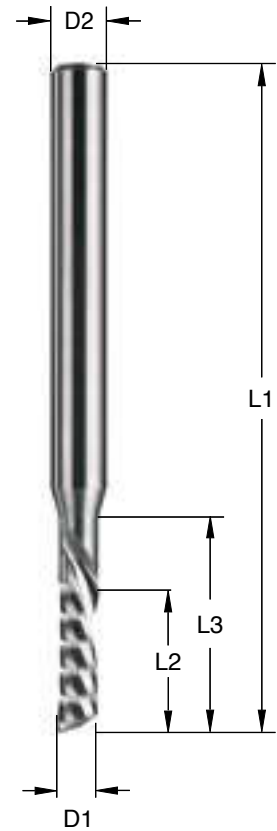

Durchmesserbereich:
1,0 bis 20,0 mm
diameter range:
1,0 to 20,0 mm

Mögliche Beschichtungen:
TLX - Standard
ALX - auf Anfrage
possible coatings:
TLX - Standard
ALX - on demand

Die Preise entnehmen Sie bitte unserer aktuellen Preisliste.
Please take prices out of our actual price list.

Bei der Bestellung bitte die Bestellnummer angeben: Best.Nr.: z.B. 131K050060 und wenn gewünscht Beschichtung: z.B. TLX.
Please indicate order number: e.g. 111L050050 and if wanted COATING: e.g. TLX.

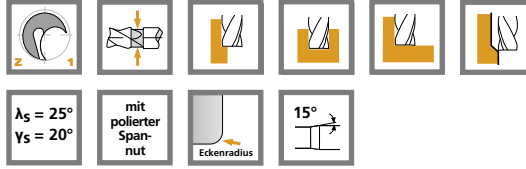

Durchmesserbereich:
0,2 bis 1,0 mm
diameter range:
0,2 to 1,0 mm

Mögliche Beschichtungen:
TLX - Standard
ALX - auf Anfrage
possible coatings:
TLX - Standard
ALX - on demand

BESTELL-NUMMER ORDER NUMBER		D1 mm	D2 h6 mm	L2 mm	L1 +2 mm	L3 mm	ER mm		
0,2	130M002030	0,2	3	0,2	40		0,05		
	130M002030-2	0,2	3	0,2	40	2	0,05		
	130MK002030	0,2	3	0,6	40		0,05		
0,3	130M003030	0,3	3	0,3	40		0,05		
	130M003030-3	0,3	3	0,3	40	3	0,05		
	130MK003030	0,3	3	0,6	40		0,05		
0,4	130M004030	0,4	3	0,6	40		0,05		
	130M004030-4	0,4	3	0,6	40	4	0,05		
0,5	130M005030	0,5	3	0,8	40		0,05		
	130MK005030	0,5	3	0,8	40	1,2	0,05		
	130M005030-5	0,5	3	0,8	40	5	0,05		
	130ML005030	0,5	3	2	40		0,05		
0,6	130M006030	0,6	3	1,2	40		0,05		
	130M006030-6	0,6	3	1,2	40	6	0,05		
	130ML006030	0,6	3	2,4	40		0,05		
0,8	130M008030	0,8	3	1,5	40		0,05		
	130M008030-8	0,8	3	1,5	40	8	0,05		
	130ML008030	0,8	3	3	40		0,05		
1,0	130M010030	1	3	2	40		0,05		
	130M010030-10	1	3	2	40	10	0,05		
	130ML010030	1	3	4	40		0,05		

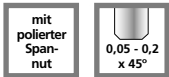

	BESTELL-NUMMER ORDER NUMBER	D1 mm	D2 h6 mm	D3 mm	L2 mm	L1 +2 mm	W°		
2,0	130FAS90-020-2	2	6	6	2	60	90		
	130FAS90-020-3	2	6	6	3	60	90		
	130FAS90-020-5	2	6	6	5	60	90		
	130FAS90-020-8	2	6	6	8	60	90		
3,0	130FAS90-030-3	3	6	6	3	60	90		
	130FAS90-030-4	3	6	6	4	60	90		
	130FAS90-030-5	3	6	6	5	60	90		
	130FAS90-030-7	3	6	6	7	60	90		
	130FAS90-030-10	3	6	6	10	60	90		
3,2	130FAS120-032-8	3,2	6	6	8	60	120		
4,0	130FAS90-040-3	4	6	6	3	60	90		
	130FAS90-040-4	4	6	6	4	60	90		
	130FAS90-040-6	4	6	6	6	60	90		
	130FAS90-040-10	4	6	6	10	60	90		
	130FAS90-840-10	4	8	8	10	63	90		
4,3	130FAS120-043-12	4,3	8	8	12	63	120		
5,3	130FAS120-053-12	5,3	10	10	12	72	120		
6,0	130FAS90-060-10	6	8	8	10	63	90		
	130FAS90-10060-10	6	10	10	10	72	90		
6,4	130FAS120-064-12	6,4	12	10	12	83	120		



Durchmesserbereich:
2,0 bis 6,4 mm
diameter range:
2,0 to 6,4 mm

Mögliche Beschichtungen:
TLX - Standard
ALX - auf Anfrage
possible coatings:
TLX - Standard
ALX - on demand

Andere Senkwinkel auf Anfrage.
Special countersink angle on demand.

Die Preise entnehmen Sie bitte unserer aktuellen Preisliste.
Please take prices out of our actual price list.

Bei der Bestellung bitte die Bestellnummer angeben: Best.Nr.: z.B. 130FAS90-040-3 und wenn gewünscht Beschichtung: z.B. TLX.
Please indicate order number: e.g. 130FAS90-060-10 and if wanted COATING: e.g. TLX.

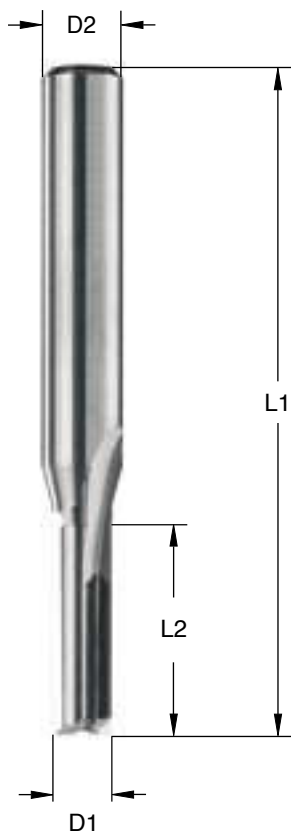
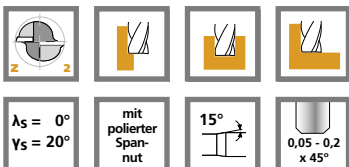

Durchmesserbereich:
2,0 bis 20,0 mm
diameter range:
2,0 to 20,0 mm

Mögliche Beschichtungen:
TLX - Standard
ALX - auf Anfrage
possible coatings:
TLX - Standard
ALX - on demand

	BESTELL-NUMMER ORDER NUMBER	D1 mm	D2 h6 mm	L2 mm	L1 +2 mm				
2,0	100020020	2	2	8	40				
	100KK020	2	3	3	50				
	100A020030	2	3	10	50				
3,0	100030030	3	3	12	40				
	100KK030	3	3	4	50				
	100K030030	3	3	10	50				
	100L030030	3	3	16	60				
	100A030060	3	6	12	50				
4,0	100040040	4	4	14	40				
	100KK040	4	4	5	50				
	100K040040	4	4	12	50				
	100L040040	4	4	18	60				
	100A040060	4	6	14	50				
5,0	100KK050	5	5	6	50				
	100050050	5	5	16	50				
	100H050050	5	5	20	60				
	100L050050	5	5	25	75				
	100A050060	5	6	16	50				
6,0	100KK060	6	6	7	50				
	100060060	6	6	18	50				
	100H060060	6	6	25	65				
	100L060060	6	6	35	75				
	100A060080	6	8	20	63				
8,0	100KK080	8	8	9	50				
	100080080	8	8	20	63				
	100H080080	8	8	30	75				
100L080080	8	8	40	100					
10,0	100100100	10	10	25	72				
12,0	100120120	12	12	30	83				
16,0	100160160	16	16	35	92				
20,0	100200200	20	20	45	104				

Die Preise entnehmen Sie bitte unserer aktuellen Preisliste.
Please take prices out of our actual price list.

Bei der Bestellung bitte die Bestellnummer angeben: Best.Nr.: z.B. 100KK080 und wenn gewünscht Beschichtung: z.B. TLX.
Please indicate order number: e.g. 100A060080 and if wanted COATING: e.g. TLX.

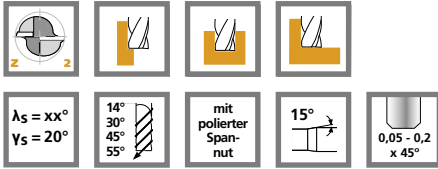

BESTELL-NUMMER ORDER NUMBER	Spirale helix ° / λs	D1 mm	D2 h6 mm	L2 mm	L1 +2 mm
2,0 102020020-	14 / 30 / 45 / 55	2	2	8	40
102KK020-	14 / 30 / 45 / 55	2	3	3	50
102A020030-	14 / 30 / 45 / 55	2	3	10	50
3,0 102030030-	14 / 30 / 45 / 55	3	3	12	40
102KK030-	14 / 30 / 45 / 55	3	3	4	50
102K030030-	14 / 30 / 45 / 55	3	3	10	50
102L030030-	14 / 30 / 45 / 55	3	3	16	60
102A030060-	14 / 30 / 45 / 55	3	6	12	50
4,0 102040040-	14 / 30 / 45 / 55	4	4	14	40
102KK040-	14 / 30 / 45 / 55	4	4	5	50
102K040040-	14 / 30 / 45 / 55	4	4	12	50
102L040040-	14 / 30 / 45 / 55	4	4	18	60
102A040060-	14 / 30 / 45 / 55	4	6	14	50
5,0 102KK050-	14 / 30 / 45 / 55	5	5	6	50
102050050-	14 / 30 / 45 / 55	5	5	16	50
102H050050-	14 / 30 / 45 / 55	5	5	20	60
102L050050-	14 / 30 / 45 / 55	5	5	25	75
102A050060-	14 / 30 / 45 / 55	5	6	16	50
6,0 102KK060-	14 / 30 / 45 / 55	6	6	7	50
102060060-	14 / 30 / 45 / 55	6	6	18	50
102H060060-	14 / 30 / 45 / 55	6	6	25	65
102L060060-	14 / 30 / 45 / 55	6	6	35	75
102A060080-	14 / 30 / 45 / 55	6	8	20	63
8,0 102KK080-	14 / 30 / 45 / 55	8	8	9	50
102080080-	14 / 30 / 45 / 55	8	8	20	63
102H080080-	14 / 30 / 45 / 55	8	8	30	75
102L080080-	14 / 30 / 45 / 55	8	8	40	100
10,0 102100100-	14 / 30 / 45 / 55	10	10	25	72
12,0 102120120-	14 / 30 / 45 / 55	12	12	30	83
16,0 102160160-	14 / 30 / 45 / 55	16	16	35	92
20,0 102200200-	14 / 30 / 45 / 55	20	20	45	104

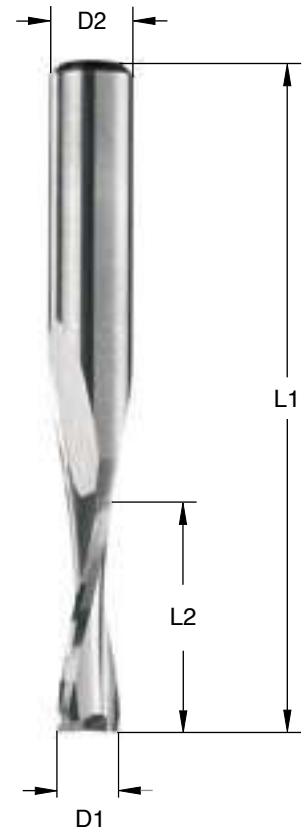

Durchmesserbereich:
2,0 bis 20,0 mm
diameter range:
2,0 to 20,0 mm

Mögliche Beschichtungen:
TLX - Standard
ALX - auf Anfrage
possible coatings:
TLX - Standard
ALX - on demand

Die Preise entnehmen Sie bitte unserer aktuellen Preisliste.
Please take prices out of our actual price list.

Bei der Bestellung bitte die Bestellnummer angeben: Best.Nr.: z.B. 102L080080-30 und wenn gewünscht Beschichtung: z.B. TLX.
Please indicate order number: e.g. 102KK080-55 and if wanted COATING: e.g. TLX.

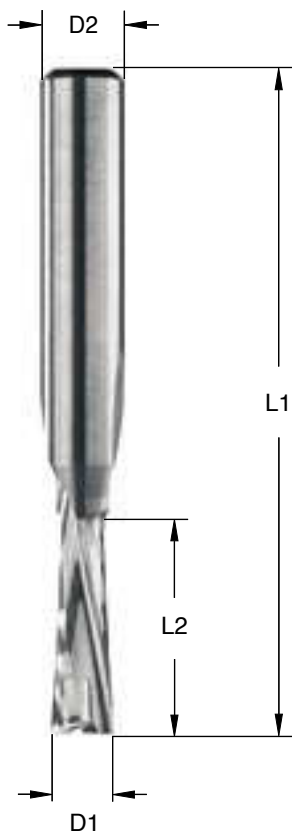
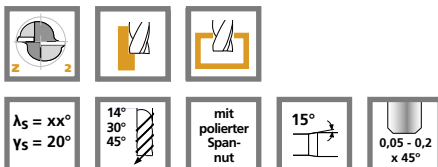

Durchmesserbereich:
2,0 bis 20,0 mm
diameter range:
2,0 to 20,0 mm

Mögliche Beschichtungen:
TLX - Standard
ALX - auf Anfrage
possible coatings:
TLX - Standard
ALX - on demand

	BESTELL-NUMMER ORDER NUMBER	Spirale helix ° / λs	D1 mm	D2 h6 mm	L2 mm	L1 +2 mm
2,0	104020020-	14 / 30 / 45	2	2	8	40
	104KK020-	14 / 30 / 45	2	3	3	50
	104A020030-	14 / 30 / 45	2	3	10	50
3,0	104030030-	14 / 30 / 45	3	3	12	40
	104KK030-	14 / 30 / 45	3	3	4	50
	104K030030-	14 / 30 / 45	3	3	10	50
	104L030030-	14 / 30 / 45	3	3	16	60
	104A030060-	14 / 30 / 45	3	6	12	50
4,0	104040040-	14 / 30 / 45	4	4	14	40
	104KK040-	14 / 30 / 45	4	4	5	50
	104K040040-	14 / 30 / 45	4	4	12	50
	104L040040-	14 / 30 / 45	4	4	18	60
	104A040060-	14 / 30 / 45	4	6	14	50
5,0	104KK050-	14 / 30 / 45	5	5	6	50
	104050050-	14 / 30 / 45	5	5	16	50
	104H050050-	14 / 30 / 45	5	5	20	60
	104L050050-	14 / 30 / 45	5	5	25	75
	104A050060-	14 / 30 / 45	5	6	16	50
6,0	104KK060-	14 / 30 / 45	6	6	7	50
	104060060-	14 / 30 / 45	6	6	18	50
	104H060060-	14 / 30 / 45	6	6	25	65
	104L060060-	14 / 30 / 45	6	6	35	75
	104A060080-	14 / 30 / 45	6	8	20	63
8,0	104KK080-	14 / 30 / 45	8	8	9	50
	104080080-	14 / 30 / 45	8	8	20	63
	104H080080-	14 / 30 / 45	8	8	30	75
	104L080080-	14 / 30 / 45	8	8	40	100
10,0	104100100-	14 / 30 / 45	10	10	25	72
12,0	104120120-	14 / 30 / 45	12	12	30	83
16,0	104160160-	14 / 30 / 45	16	16	35	92
20,0	104200200-	14 / 30 / 45	20	20	45	104

Die Preise entnehmen Sie bitte unserer aktuellen Preisliste.
Please take prices out of our actual price list.

Bei der Bestellung bitte die Bestellnummer angeben: Best.Nr.: z.B. 104100100-14 und wenn gewünscht Beschichtung: z.B. TLX.
Please indicate order number: e.g. 104160160-45 and if wanted COATING: e.g. TLX.

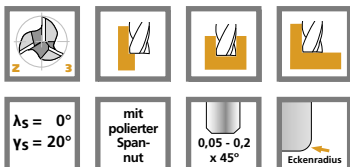

BESTELL-NUMMER ORDER NUMBER		D1 mm	D2 h6 mm	L2 mm	L1 +2 mm	ER mm			
3,0	101030030	3	3	12	40				
	101DK030030	3	3	12	40	0,2			
	101K030030	3	3	10	50				
	101L030030	3	3	16	60				
4,0	101040040	4	4	14	40				
	101DK040040	4	4	14	40	0,2			
	101K040040	4	4	12	50				
	101L040040	4	4	16	60				
5,0	101050050	5	5	16	50				
	101DK050050	5	5	16	50	0,2			
	101L050050	5	5	28	60				
6,0	101060060	6	6	18	50				
	101DK060060	6	6	18	50	0,2			
	101L060060	6	6	35	75				
8,0	101080080	8	8	20	63				
	101DK080080	8	8	20	63	0,2			
	101L080080	8	8	40	100				
10,0	101100100	10	10	25	72				
	101DK100100	10	10	25	72	0,2			
12,0	101120120	12	12	30	83				
16,0	101160160	16	16	35	92				
20,0	101200200	20	20	45	104				

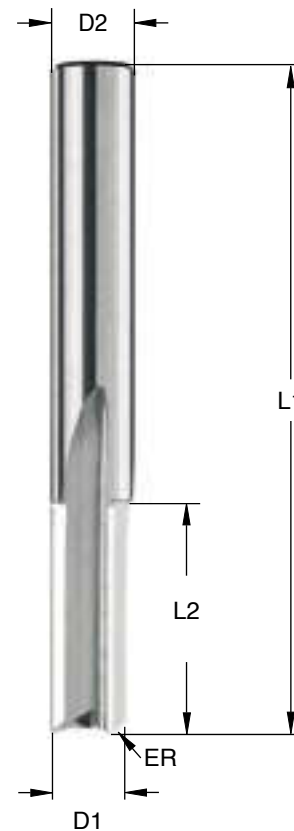

Durchmesserbereich:
3,0 bis 20,0 mm
diameter range:
3,0 to 20,0 mm

Mögliche Beschichtungen:
TLX - Standard
ALX - auf Anfrage
possible coatings:
TLX - Standard
ALX - on demand

Die Preise entnehmen Sie bitte unserer aktuellen Preisliste.
Please take prices out of our actual price list.

Bei der Bestellung bitte die Bestellnummer angeben: Best.Nr.: z.B. 101DK030030 und wenn gewünscht Beschichtung: z.B. TLX.
Please indicate order number: e.g. 101160160 and if wanted COATING: e.g. TLX.

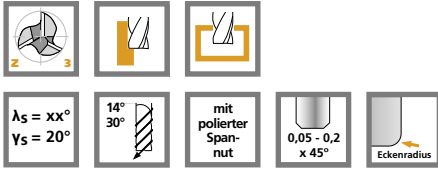

BESTELL-NUMMER ORDER NUMBER		Spirale helix ° / λs	D1 mm	D2 h6 mm	L2 mm	L1 +2 mm	ER mm
3,0	105030030	30	3	3	12	40	
	105DK030030-	14 / 30	3	3	12	40	0,2
4,0	105040040	30	4	4	14	40	
	105DK040040-	14 / 30	4	4	14	40	0,2
5,0	105050050	30	5	5	16	50	
	105DK050050-	14 / 30	5	5	16	50	0,2
6,0	105060060	30	6	6	18	50	
	105DK060060-	14 / 30	6	6	18	50	0,2
8,0	105080080	30	8	8	20	63	
	105DK080080-	14 / 30	8	8	20	63	0,2
10,0	105100100	30	10	10	25	72	
	105DK100100-	14 / 30	10	10	25	72	0,2
12,0	105120120	30	12	12	30	83	
16,0	105160160	30	16	16	35	92	
20,0	105200200	30	20	20	45	104	

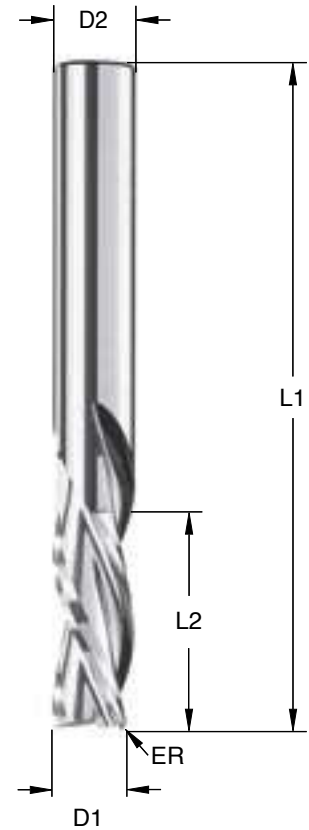

Durchmesserbereich:
3,0 bis 20,0 mm
diameter range:
3,0 to 20,0 mm

Mögliche Beschichtungen:
TLX - Standard
ALX - auf Anfrage
possible coatings:
TLX - Standard
ALX - on demand

Die Preise entnehmen Sie bitte unserer aktuellen Preisliste.
Please take prices out of our actual price list.

Bei der Bestellung bitte die Bestellnummer angeben: Best.Nr.: z.B. 105DK040040-30 und wenn gewünscht Beschichtung: z.B. TLX.
Please indicate order number: e.g. 105100100-30 and if wanted COATING: e.g. TLX.

UNIVERSAL-LINE

FÜR DIE BEARBEITUNG
VON SCHAUM, PE UND PU

FOR THE MACHINING OF
FOAM, PE AND PU

UNIVERSAL-LINE

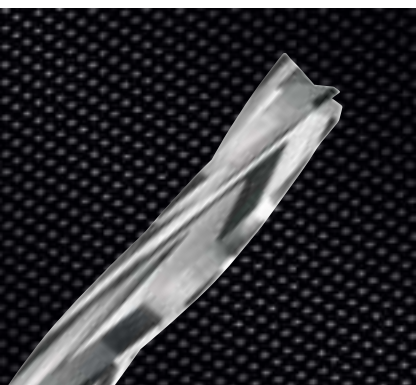

103DFO

Diese Werkzeuge sind mit speziellen Geometrien für die Bearbeitung von PE- und PU-Schäumen ausgestattet und auch in sehr langer Ausführung lieferbar. Sie erlauben die Bearbeitung senkrechter Kanten ohne Flusen und Fasern. Die Geometrie an der Kopfschneide vermeidet Eintauchabdrücke am Boden der Bauteiltasche.

DEKOFOAM-FRÄSER Z3 14°

- mit 14° Spirale
- mit definiertem Kantenradius
- mit sanfter Zuggeometrie
- mit Protect-Formel
- auch linksgedrallt lieferbar

Schäume aus vernetztem und unernetztem PE oder geschäumtem PU werden in der Verpackungsindustrie, der Orthopädietechnik und in der Automobilindustrie eingesetzt. Hier müssen auch spitze Ecken sauber mit abgetrennt werden.

Die dafür entwickelten Fräser werden in der Ausführung mit Spirale im Winkel von 14 Grad, definiertem Kantenradius, sanfter Zuggeometrie und mit Protect-Formel angeboten.

Auf Anfrage sind andere Werkzeuge auch linksgedrallt lieferbar.

103DFO

These tools are equipped with special geometries for processing PE and PU foams and are also available in very long version. These tools allow treatment of vertical borders without lint and fibers. The geometry at the head blade prevents sinking imprints at the bottom of the component sack.

DEKOFOAM-MILLING TOOL Z3 14°

- with 14° spiral
- with defined edge radius
- with soft pulling geometry
- with Protect-Formula
- also available with left-handed twist

Foams of cured and uncured PE or foamed PU find application in packing industry, orthopedic prosthetics and automotive industry. Here sharp edges must be cleanly cut.

The milling tools developed for this are available as models with spiral angle of 14°, defined edge radius, soft pulling and with Protect Formula.

All our tools are also available with left-hand cutting on special demand.



$\lambda_s = 14^\circ$
 $\gamma_s = 18^\circ$

mit
polierter
Span-
nut

BESTELL-NUMMER ORDER NUMBER		D1 mm	D2 h6 mm	L2 mm	L1 +2 mm	L3 mm	R mm		
3,0	103DFOR030	3	3	15	75	40	1,5		
4,0	103DFOR040	4	4	15	75	40	2,0		
	103DFORL040	4	4	20	75	40	2,0		
	103DFORXL040	4	4	22	100		2,0		
	103DFORSXL040	4	4	20	125	100	2,0		
	103DFORXXL040	4	4	15	150	100	2,0		
5,0	103DFOR050	5	5	15	100	50	2,5		
	103DFORL050	5	5	20	100	65	2,5		
6,0	103DFORK060	6	6	25	100		3,0		
	103DFORKF060	6	6	25	100	75	3,0		
	103DFORSL060	6	6	42	100	75	3,0		
	103DFOR060	6	6	20	125	75	3,0		
	103DFORXL060	6	6	42	150		3,0		
	103DFORL060	6	6	20	150	100	3,0		
8,0	103DFOR080	8	8	42	100	75	4,0		
	103DFORSL080	8	8	52	100	75	4,0		
	103DFORL080	8	8	20	150	100	4,0		
	103DFORXL080	8	8	52	150		4,0		
	103DFORSXL080	8	8	52	150	115	4,0		
10,0	103DFOR100	10	10	50	120	85	5,0		
	103DFORL100	10	10	25	150	115	5,0		
	103DFORXL100	10	10	52	150		5,0		
	103DFORSXL100	10	10	52	150	115	5,0		
12,0	103DFOR120	12	12	50	125	90	6,0		
	103DFORL120	12	12	25	150	115	6,0		
	103DFORXL120	12	12	50	170	135	6,0		
16,0	103DFOR160	16	16	50	125	85	8,0		
	103DFORL160	16	16	70	150	125	8,0		
	103DFORXL160	16	16	80	200	170	8,0		

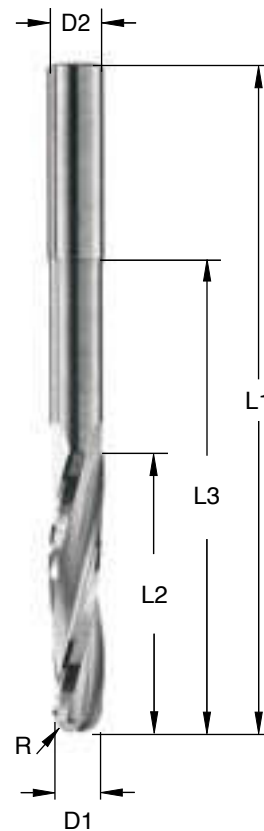

Durchmesserbereich:
3,0 bis 16,0 mm
diameter range:
3,0 to 16,0 mm

Die Preise entnehmen Sie bitte unserer aktuellen Preisliste.
Please take prices out of our actual price list.

Bei der Bestellung bitte die Bestellnummer angeben: Best.Nr.: z.B. 103DFOR160.
Please indicate order number: e.g. 103DFORL120.

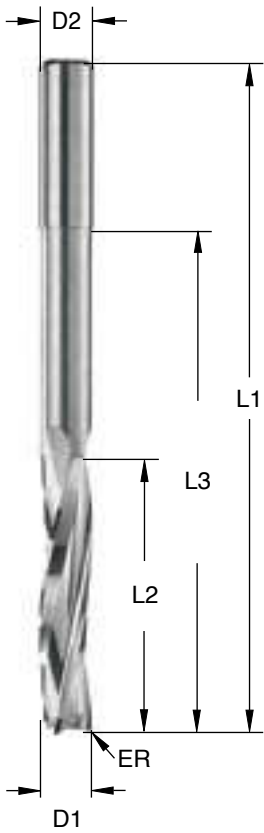
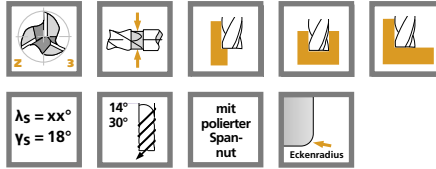

Durchmesserbereich:
3,0 bis 16,0 mm
diameter range:
3,0 to 16,0 mm

	BESTELL-NUMMER ORDER NUMBER	Spirale helix ° / λs	D1 mm	D2 h6 mm	L2 mm	L1 +2 mm	L3 mm	ER mm
3,0	103DFO030	14	3	3	15	75	40	
	103DK030030-	14 / 30	3	3	12	40		0,2
4,0	103DFO040	14	4	4	15	75	40	
	103DFOL040	14	4	4	20	75	40	
	103DFOXL040	14	4	4	22	100		
	103DFOSXL040	14	4	4	20	125	100	
	103DFOXXL040	14	4	4	15	150	100	
	103DK040040-	14 / 30	4	4	14	40		0,2
5,0	103DFO050	14	5	5	15	100	50	
	103DFOL050	14	5	5	20	100	65	
	103DK050050-	14 / 30	5	5	16	50		0,2
6,0	103DFOK060	14	6	6	25	100		
	103DFOKF060	14	6	6	25	100	75	
	103DFO060	14	6	6	20	125	75	
	103DFOL060	14	6	6	20	150	100	
	103DFOSL060	14	6	6	42	100	75	
	103DFOXL060	14	6	6	42	150		
	103DK060060-	14 / 30	6	6	18	50		0,2
8,0	103DFO080	14	8	8	42	100	75	
	103DFOL080	14	8	8	20	150	100	
	103DFOSL080	14	8	8	52	100	75	
	103DFOXL080	14	8	8	52	150		
	103DFOSXL080	14	8	8	52	150	115	
	103DK080080-	14 / 30	8	8	20	63		0,2
10,0	103DFO100	14	10	10	50	120	85	
	103DFOL100	14	10	10	25	150	115	
	103DFOXL100	14	10	10	52	150		
	103DFOSXL100	14	10	10	52	150	115	
	103DK100100-	14 / 30	10	10	25	72		0,2
12,0	103DFO120	14	12	12	50	125	90	
	103DFOL120	14	12	12	25	150	115	
	103DFOXL120	14	12	12	50	170	135	
16,0	103DFO160	14	16	16	50	125	85	
	103DFOL160	14	16	16	70	150	125	
	103DFOXL160	14	16	16	80	200	170	

Die Preise entnehmen Sie bitte unserer aktuellen Preisliste.
Please take prices out of our actual price list.

UNIVERSAL-LINE

FÜR DIE
MEDIZINTECHNIK

FOR MEDICAL
TECHNOLOGY



PEEK
PEEK

UHM
UHM

PA
PA

PE
PE

PP
PP

PS
PS

PUR
PUR

Gummi
Rubber

Latex
Latex

HUFSCHMIED
ZERSpanungSSYSTEME



UNIVERSAL-LINE

ZUR BEARBEITUNG VON
PEEK, UHM, PE

FOR THE MACHINING OF
PEEK, UHM, PE

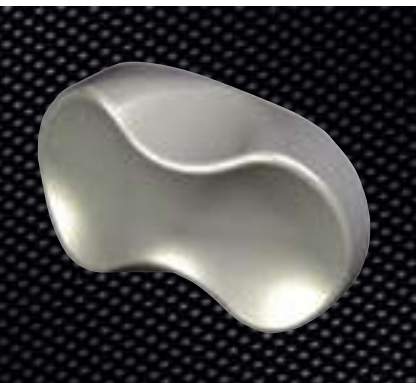

UHM / PE

Auch hier halten ständig neue Werkstoffe Einzug. PEEK oder PTFE zum Beispiel, eröffnen bei Implantaten oder medizinischen Bauteilen ganz neue Möglichkeiten.

Werkstoffoptimierte Werkzeuge von Hufschmied unterscheiden sich von bisher handelsüblichen Ausführungen durch hohe Oberflächengüten und die Gratfreiheit nach dem Bohren und Fräsen. Dadurch wird eine Nachbearbeitung oft überflüssig. Unsere prozessoptimierten Werkzeuge verkürzen die Bearbeitungszeiten ohne Qualitätseinbußen und werden zudem auch den Forderungen nach immer kleineren Werkzeugen gerecht.

UHM / PE

New materials also appear here permanently. PEEK or PTFE for example, establish very new options for implants or medical components.

The material-optimized Hufschmied-tools differ from previous standard models in a high surface finish and the non-existence of burrs after drilling and milling. Therefore a post-processing is often unnecessary. Our process-optimized tools reduce the processing times without quality losses and come in addition up to the demand of more small tools.



$\lambda_s = 40^\circ$
 $\gamma_s = 22^\circ$

mit
polierter
Span-
nut

BESTELL-NUMMER ORDER NUMBER		D1 mm	D2 h6 mm	L2 mm	L1 +2 mm	L3 mm			
2,0	95PEL02	2	3	10	60				
3,0	95PE03	3	3	10	60				
	95PEXL03	3	3	10	75	25			
4,0	95PE04	4	4	12	60				
	95PEXL04	4	4	12	75	25			
5,0	95PE05	5	5	13	62				
	95PEXL05	5	5	13	75	30			
6,0	95PE06	6	6	16	60				
	95PEL06	6	6	16	75	35			
8,0	95PE08	8	8	19	63				
	95PEXL08	8	8	19	75	35			
10,0	95PE10	10	10	22	72				
	95PEL10	10	10	22	89	35			
12,0	95PEL12	12	12	26	100	45			
16,0	95PEL16	16	16	19	100	45			

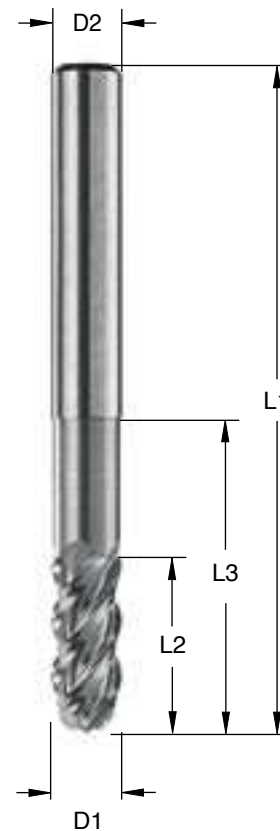

Durchmesserbereich:
2,0 bis 16,0 mm
diameter range:
2,0 to 16,0 mm

Mögliche Beschichtungen:
ALX - Standard
DIP - auf Anfrage
possible coatings:
ALX - Standard
DIP - on demand

Die Preise entnehmen Sie bitte unserer aktuellen Preisliste.
Please take prices out of our actual price list.

Bei der Bestellung bitte die Bestellnummer angeben: Best.Nr.: z.B. 95PE03 und wenn gewünscht Beschichtung: z.B. ALX.
Please indicate order number: e.g. 95PEL12 and if wanted COATING: e.g. ALX.

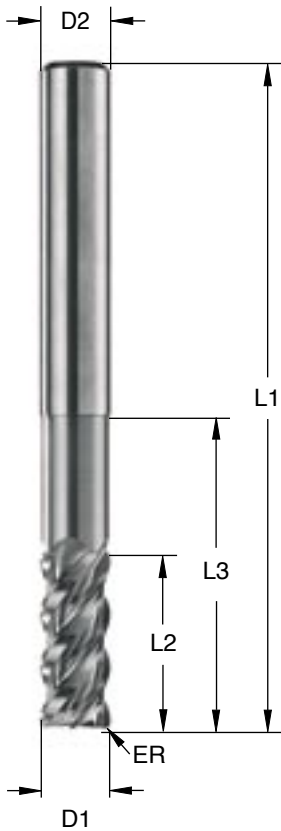
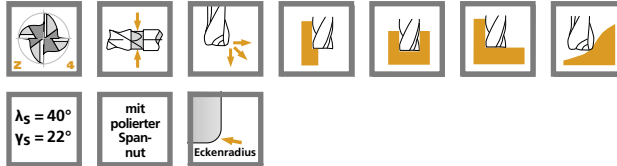

Durchmesserbereich:
 2,0 bis 16,0 mm
diameter range:
 2,0 to 16,0 mm

Mögliche Beschichtungen:
 ALX - Standard
 DIP - auf Anfrage
possible coatings:
 ALX - Standard
 DIP - on demand

BESTELL-NUMMER ORDER NUMBER		D1 mm	D2 h6 mm	L2 mm	L1 +2 mm	L3 mm	ER mm		
2,0	91PEL02	2	3	10	60		0,15		
3,0	91PE03	3	3	10	60		0,15		
	91PEXL03	3	3	10	75	25	0,15		
4,0	91PE04	4	4	12	60		0,2		
	91PEXL04	4	4	12	75	25	0,2		
5,0	91PE05	5	5	13	62		0,3		
	91PEXL05	5	5	13	75	30	0,3		
6,0	91PE06	6	6	16	60		0,5		
	91PEL06	6	6	16	75	35	0,5		
8,0	91PE08	8	8	19	63		0,5		
	91PEXL08	8	8	19	75	35	0,5		
10,0	91PE10	10	10	22	72		0,5		
	91PEL10	10	10	22	89	35	1,0		
12,0	91PEL1205	12	12	26	100	45	0,5		
	91PEL1210	12	12	26	100	45	1,0		
16,0	91PEL1605	16	16	26	100	45	0,5		
	91PEL1610	16	16	26	100	45	1,0		

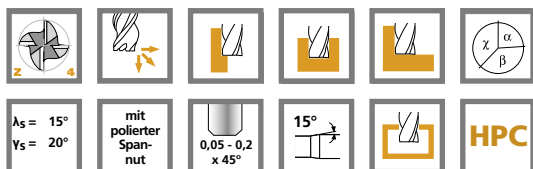

BESTELL-NUMMER ORDER NUMBER		D1 mm	D2 h6 mm	L2 mm	L1 +2 mm				
2,0	91BD02	2	3	6	40				
3,0	91BD03	3	3	10	50				
	91BDL03	3	3	18	60				
	91BDXL03	3	3	25	75				
4,0	91BD04	4	4	11	40				
	91BDL04	4	4	20	60				
	91BDXL04	4	4	32	75				
5,0	91BD05	5	5	13	50				
	91BDL05	5	5	25	62				
	91BDXL05	5	5	38	100				
6,0	91BD06	6	6	16	50				
	91BDL06	6	6	30	75				
	91BDXL06	6	6	40	100				
8,0	91BD08	8	8	19	63				
	91BDL08	8	8	35	79				
	91BDXL08	8	8	45	100				
10,0	91BD10	10	10	22	72				
	91BDL10	10	10	40	89				
	91BDXL10	10	10	50	120				
12,0	91BD12	12	12	26	83				
	91BDL12	12	12	50	100				
	91BDXL12	12	12	60	150				
16,0	91BD16	16	16	32	92				
	91BDL16	16	16	58	125				
	91BDXL16	16	16	75	150				
20,0	91BD20	20	20	38	104				
	91BDL20	20	20	60	125				
	91BDXL20	20	20	75	150				

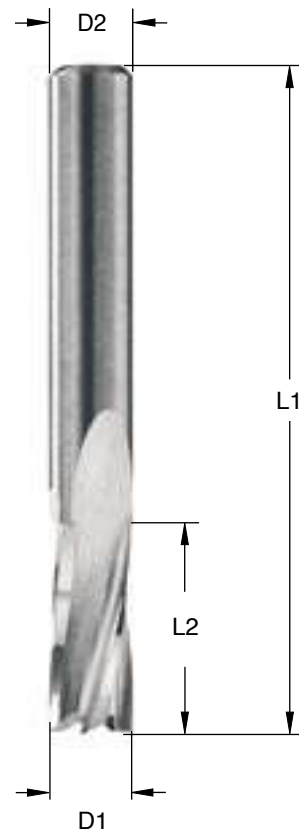

Durchmesserbereich:
2,0 bis 20,0 mm
diameter range:
2,0 to 20,0 mm

Mögliche Beschichtungen:
TLX - Standard
TL2 - auf Anfrage
DIP - auf Anfrage
possible coatings:
TLX - Standard
TL2 - on demand
DIP - on demand

Die Preise entnehmen Sie bitte unserer aktuellen Preisliste.
Please take prices out of our actual price list.

Bei der Bestellung bitte die Bestellnummer angeben: Best.Nr.: z.B. 91BD04 und wenn gewünscht Beschichtung: z.B. TLX.
Please indicate order number: e.g. 91BDL16 and if wanted COATING: e.g. TLX.

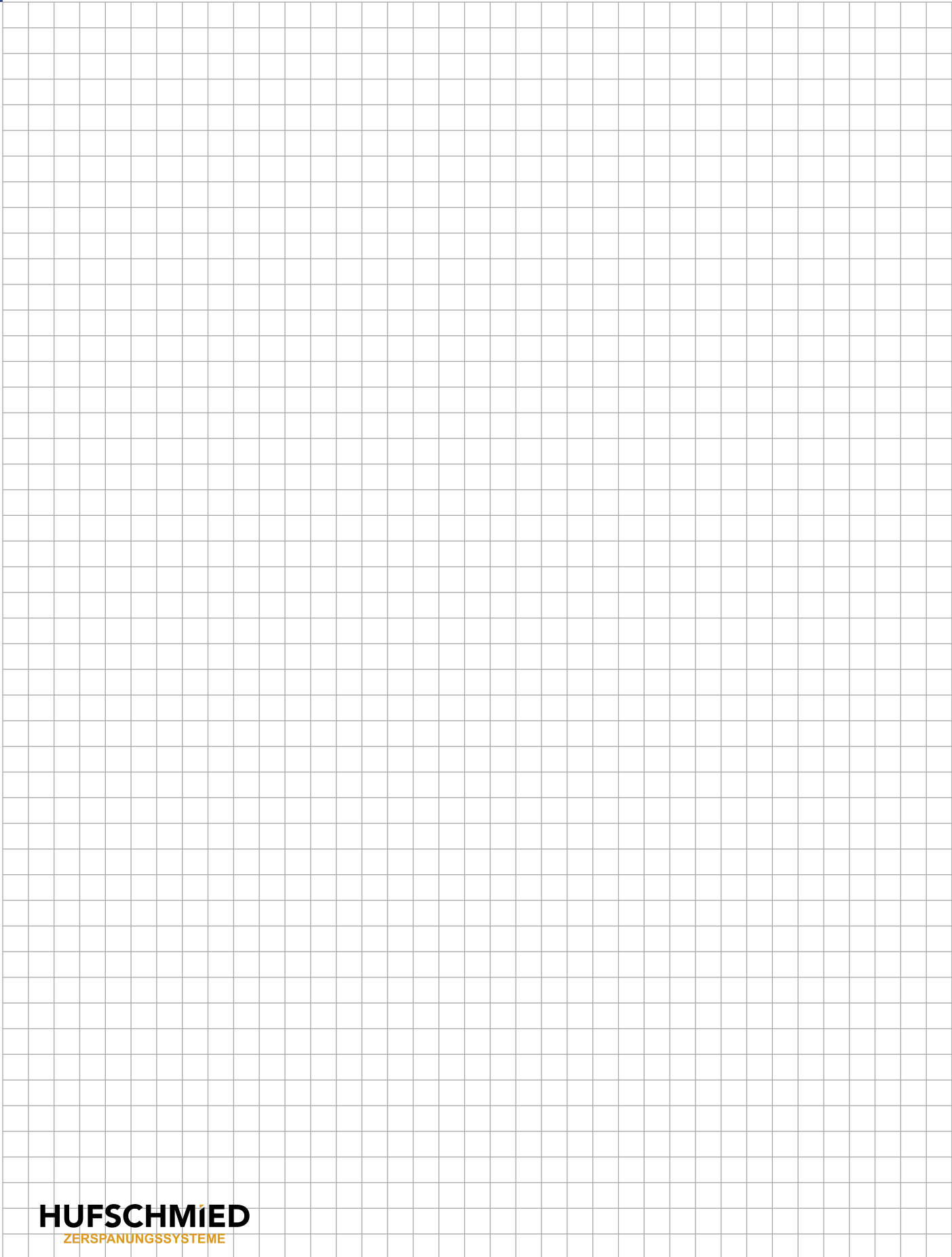

UNIVERSAL-LINE

SCHEIBENFRÄSER

DISC MILL

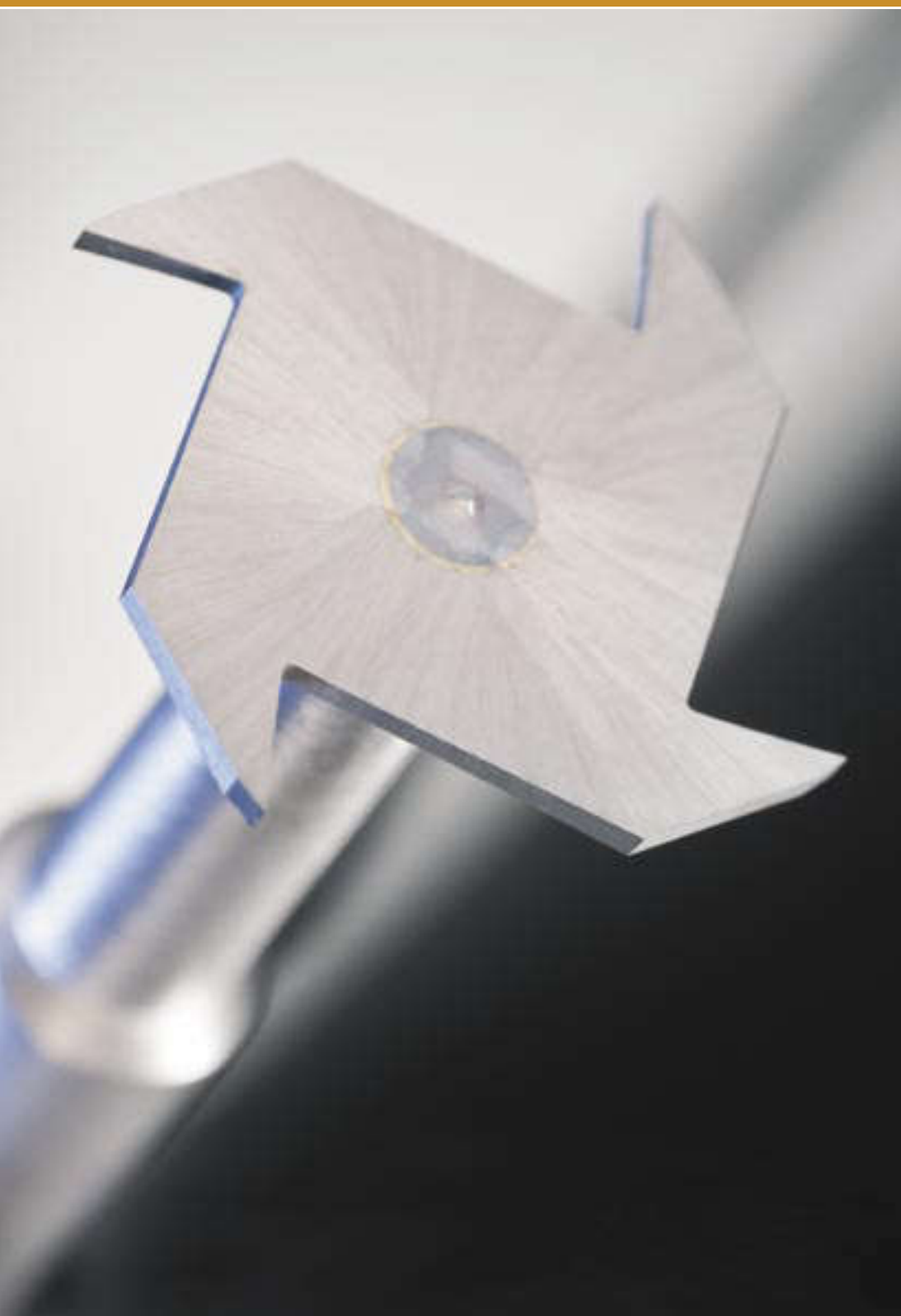

POM
POM

PA
PA

PE
PE

PP
PP

PVC
PVC

ABS
ABS

PS
PS

PUR
PUR

Gummi
Rubber

Latex
Latex

HUFSCHMIED
ZERSpanungSSYSTEME



Durchmesserbereich:
20,0 bis 30,0 mm
diameter range:
20,0 to 30,0 mm

BESTELL-NUMMER ORDER NUMBER		D1 mm	D2 h6 mm	B mm	L1 +2 mm				
20,0	120200060-2	20	6	2	50				
	120200060-4	20	6	4	50				
	120200060-6	20	6	6	50				
	120200060-8	20	6	8	50				
	120200060-10	20	6	10	50				
30,0	120300060-2	30	6	2	50				
	120300060-4	30	6	4	50				
	120300060-6	30	6	6	50				
	120300060-8	30	6	8	50				
	120300060-10	30	6	10	50				

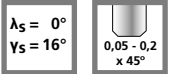

BESTELL-NUMMER ORDER NUMBER		D1 mm	D2 h6 mm	D3 mm	B mm	L1 +2 mm	L3 mm
12,0	120GM120	12	8	6	0,8	80	45
14,0	120GM140	14	8	6	0,8	80	45
16,0	120GM160	16	8	6	0,8	80	45
18,0	120GM180	18	8	6	0,8	80	45
20,0	120GM200	20	8	6	0,8	80	45
22,0	120GM220	22	8	6	0,8	80	45

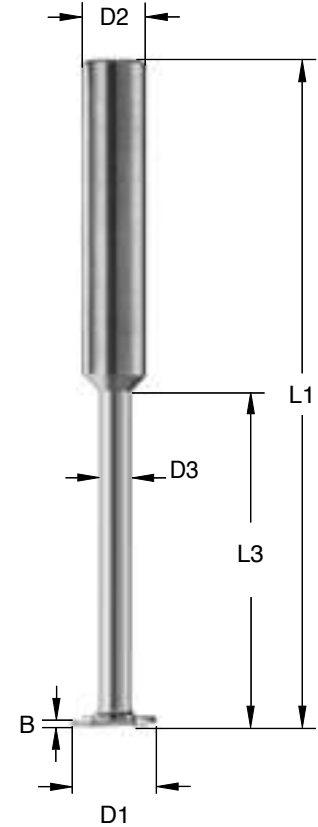

Durchmesserbereich:
12,0 bis 22,0 mm
diameter range:
12,0 to 22,0 mm

Die Preise entnehmen Sie bitte unserer aktuellen Preisliste.
Please take prices out of our actual price list.

Bei der Bestellung bitte die Bestellnummer angeben: Best.Nr.: z.B. 1120GM140.
Please indicate order number: e.g. 120GM220.

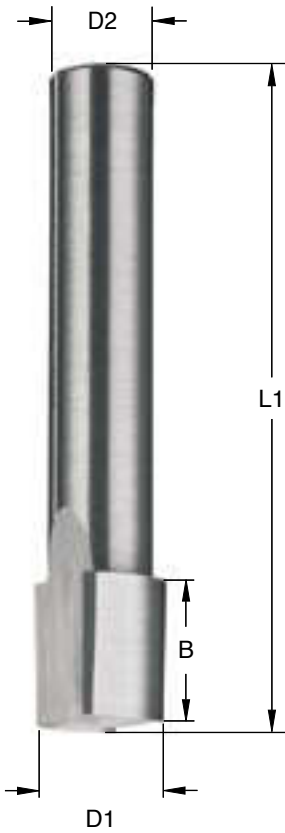

Durchmesserbereich:
6,0 bis 20,0 mm
diameter range:
6,0 to 20,0 mm

BESTELL-NUMMER ORDER NUMBER		D1 mm	D2 h6 mm	L1 +2 mm	B mm	Z			
6,0	120P060-5	6	10	75	5	2			
	120P060-10	6	10	75	10	2			
	120P060-15	6	10	75	15	2			
8,0	120P080-7	8	10	75	7	2			
	120P080-10	8	10	75	10	2			
	120P080-15	8	10	75	15	2			
	120P080-20	8	10	75	20	2			
12,0	120P120-7	12	10	75	7	2			
	120P120-10	12	10	75	10	2			
	120P120-15	12	10	75	15	2			
	120P120-20	12	10	75	20	2			
16,0	120P160-7	16	10	75	7	2			
	120P160-10	16	10	75	10	2			
	120P160-15	16	10	75	15	2			
	120P160-20	16	10	75	20	2			
20,0	120P200-7	20	10	75	7	2			
	120P200-10	20	10	75	10	2			
	120P200-15	20	10	75	15	2			
	120P200-20	20	10	75	20	2			



$\lambda_s = KV$
 $\gamma_s = 16^\circ$

BESTELL-NUMMER ORDER NUMBER	B mm	Z	Drehrichtung Turning direction	D2 mm		
30,0 1130-30002L	2	6	links	16		
1130-30002R	2	6	rechts	16		
40,0 1130-40002L	2	8	links	16		
1130-40002R	2	8	rechts	16		
50,0 1130-50002L	2	10	links	24		
1130-50002R	2	10	rechts	24		
60,0 1130-60002L	2	12	links	24		
1130-60002R	2	12	rechts	24		
80,0 1130-80003L	3	14	links	24		
1130-80003R	3	14	rechts	24		



B=Schnittbreite
B=cutting width
D2=Schaftanlagefläche
D2=shank array

Durchmesserbereich:
30,0 bis 80,0 mm

diameter range:
30,0 to 80,0 mm

BESTELL-NUMMER ORDER NUMBER	Bezeichnung Description	D mm	
1130A-30/40	Aufnahme für Scheibenfräser D30 / D 40 Tool holder	16	
1130A-50/60/80	Aufnahme für Scheibenfräser D50 / D 60 / D 80 Tool holder	24	

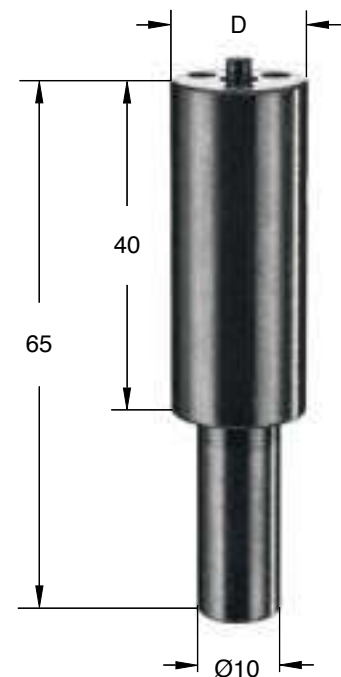

Die Preise entnehmen Sie bitte unserer aktuellen Preisliste.
Please take prices out of our actual price list.

Bei der Bestellung bitte die Bestellnummer angeben: Best.Nr.: z.B. 1130-60002L.
Please indicate order number: e.g. 1130-80003R.

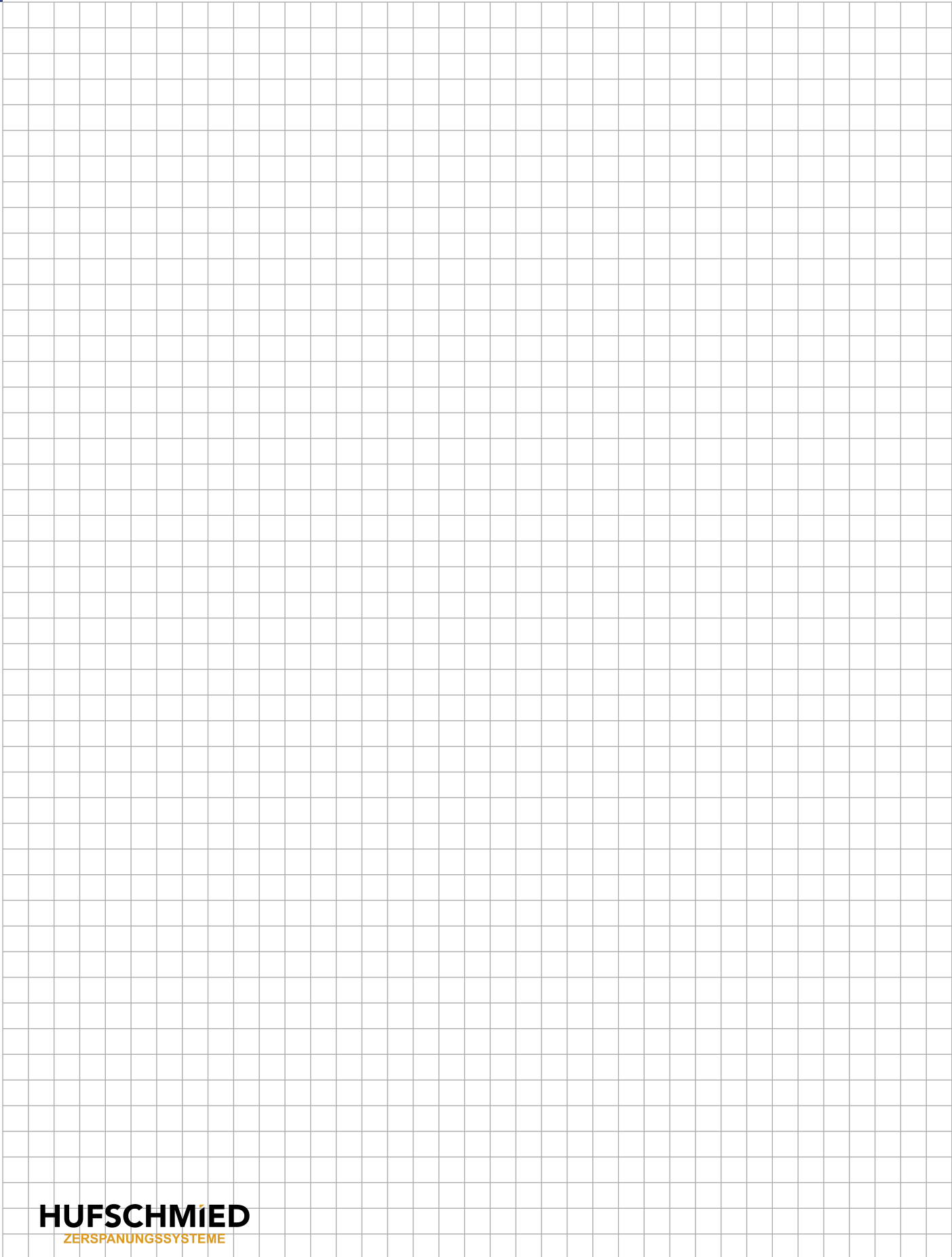

UNIVERSAL-LINE

BOHREN UND GEWINDEN
FÜR THERMO-, DURO-
PLASTE UND ELASTOMERE

*DRILLING AND THREADING
FOR THERMOPLASTICS,
CURABLE PLASTICS AND
ELASTOMERS*



POM
POM

PA
PA

PE
PE

PP
PP

PVC
PVC

ABS
ABS

PS
PS

PUR
PUR

Gummi
Rubber

Latex
Latex

HUFSCHMIED
ZERSpanungSSyStEME



UNIVERSAL-LINE

KUNSTSTOFFBOHRER
GEWINDEFÄSER

PLASTIC DRILLS
THREAD MILLS

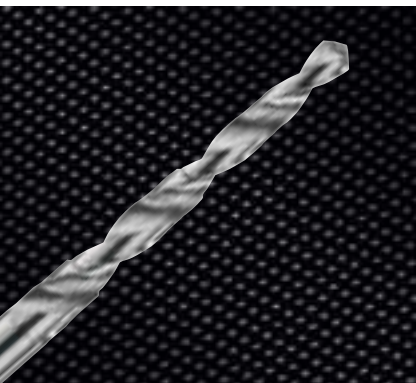
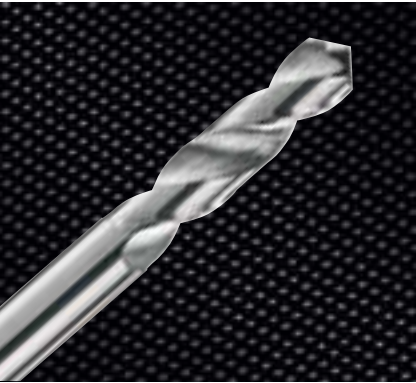

UNIVERSAL-BOHREN

Die Anforderungen an Bauteile aus Kunststoff steigen kontinuierlich. Dies gilt besonders für die Qualität von Bohrungen. Hier sind in der Serienfertigung hohe Passgenauigkeit, Konzentricität und Oberflächengüte gefragt.

Die neue Generation der KD-Kunststoffbohrer von Hufschmied erfüllt nicht nur diese Anforderungen, sondern setzt auch bei Gratfreiheit, Bearbeitungsgeschwindigkeit und Werkzeugstandzeiten neue Maßstäbe.

UNIVERSAL-DRILLING

The requirements for synthetic components rise continuously. The quality of drills is especially concerned. In the series manufacturing a high accuracy of fit, concentricity and surface quality is in demand.

The new generation of KD-synthetic drills of Hufschmied not only meets these requirements but also sets new standards in the non-existence of burrs, machining speed and tool durability.



BESTELL-NUMMER ORDER NUMBER	D1 mm	D2 h6 mm	L2 mm	L1 +2 mm				
0,5	KD201005	0,5	3	2,5	50			
0,75	KD2010075	0,75	3	4	50			
0,8	KD201008	0,8	3	5	50			
1,0	KD201010	1	3	7	50			
1,2	KD201012	1,2	3	8	50			
1,5	KD201015	1,5	3	10	50			
1,6	KD201016	1,6	3	11	50			
1,8	KD201018	1,8	3	12	50			
2,0	KD201020	2	3	14	50			
2,05	KD2010205	2,05	3	14	50			
2,5	KD201025	2,5	3	16	50			
2,8	KD201028	2,8	3	16	50			
3,0	KD201030	3	3	18	50			
3,3	KD201033	3,3	4	20	60			
3,5	KD201035	3,5	4	20	60			
3,7	KD201037	3,7	4	20	60			
4,0	KD201040	4	4	24	60			
4,2	KD201042	4,2	5	24	62			
4,5	KD201045	4,5	5	24	62			
4,65	KD2010465	4,65	5	25	62			
5,0	KD201050	5	5	28	62			
5,5	KD201055	5,5	6	28	75			
5,55	KD2010555	5,55	6	28	75			
6,0	KD201060	6	6	30	75			
6,8	KD201068	6,8	8	32	75			
7,0	KD201070	7	8	32	75			
7,45	KD2010745	7,45	8	32	75			
7,5	KD201075	7,5	8	35	100			
8,0	KD201080	8	8	40	100			
8,5	KD201085	8,5	10	45	100			
9,0	KD201090	9	10	45	100			
9,35	KD2010935	9,35	10	45	100			
9,5	KD201095	9,5	10	45	100			
10,0	KD201100	10	10	50	100			
10,2	KD201102	10,2	12	60	125			
10,5	KD201105	10,5	12	60	125			
11,0	KD201110	11	12	60	125			
11,2	KD201112	11,2	12	60	125			
11,5	KD201115	11,5	12	60	125			
12,0	KD201120	12	12	60	125			
14,0	KD201140	14	16	70	125			
15,5	KD201155	15,5	16	70	125			
16,0	KD201160	16	16	70	125			
17,5	KD201175	17,5	20	80	150			
20,0	KD201200	20	20	80	150			

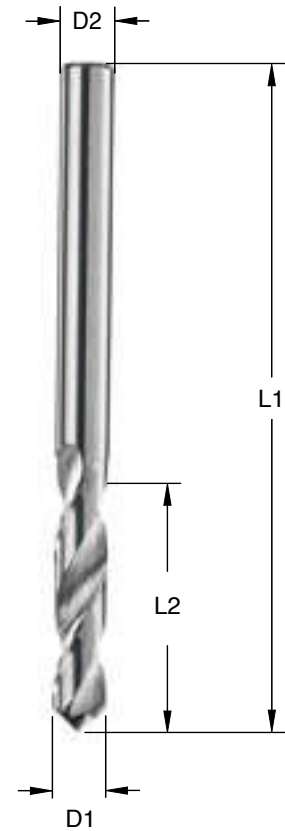

Durchmesserbereich:
0,5 bis 20,0 mm
diameter range:
0,5 to 20,0 mm

Mögliche Beschichtungen:
TLX - Standard
ALX - auf Anfrage
possible coatings:
TLX - Standard
ALX - on demand

linksdrall - linksschneidend
auf Anfrage
left helix - left cutting on demand

Die Preise entnehmen Sie bitte unserer aktuellen Preisliste.
Please take prices out of our actual price list.

Bei der Bestellung bitte die Bestellnummer angeben: Best.Nr.: z.B. KD201055 und wenn gewünscht Beschichtung: z.B. TLX.
Please indicate order number: e.g. KD201175 and if wanted COATING: e.g. TLX.

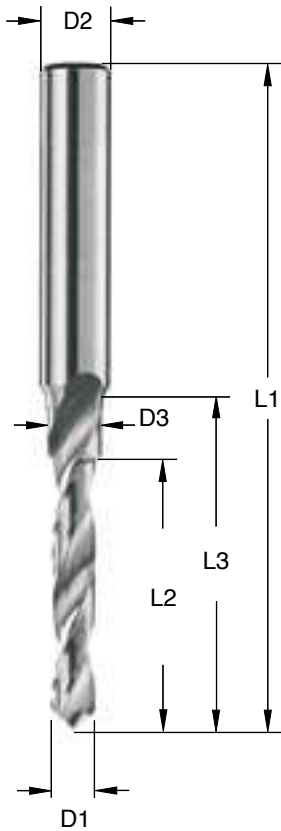

Durchmesserbereich:
0,5 bis 20,0 mm
diameter range:
0,5 to 20,0 mm

Mögliche Beschichtungen:
TLX - Standard
ALX - auf Anfrage
possible coatings:
TLX - Standard
ALX - on demand

linksdrill - linksschneidend
auf Anfrage
left helix - left cutting on demand

	BESTELL-NUMMER ORDER NUMBER	D1 mm	D2 h6 mm	D3 mm	L2 mm	L1 +2 mm	L3 mm		
0,5	KD202005	0,5	3	2,0	2,5	50	5		
0,75	KD2020075	0,75	3	2,0	4	50	8		
0,8	KD202008	0,8	3	2,0	5	50	10		
1,0	KD202010	1	3	2,5	7	50	15		
1,2	KD202012	1,2	3	2,5	8	50	16		
1,5	KD202015	1,5	3	2,5	10	50	20		
1,6	KD202016	1,6	3	2,5	11	50	20		
1,8	KD202018	1,8	3	2,5	12	50	20		
2,0	KD202020	2	6	4,5	14	60	25		
2,05	KD2020205	2,05	6	4,5	14	60	25		
2,5	KD202025	2,5	6	4,5	16	60	25		
2,8	KD202028	2,8	6	4,5	16	60	25		
3,0	KD202030	3	6	5,0	18	60	25		
3,3	KD202033	3,3	6	5,0	20	60	25		
3,5	KD202035	3,5	6	5,0	20	60	25		
3,7	KD202037	3,7	6	5,0	20	60	25		
4,0	KD202040	4	8	6,5	24	75	35		
4,2	KD202042	4,2	8	6,5	24	75	35		
4,5	KD202045	4,5	8	6,5	24	75	35		
4,65	KD2020465	4,65	8	6,5	25	75	35		
5,0	KD202050	5	8	6,5	28	75	35		
5,5	KD202055	5,5	10	8,0	28	100	40		
5,55	KD2020555	5,55	10	8,0	28	100	40		
6,0	KD202060	6	10	8,0	30	100	40		
6,8	KD202068	6,8	10	10,0	32	100	40		
7,0	KD202070	7	10	10,0	32	100	40		
7,45	KD2020745	7,45	10	10,0	32	100	40		
7,5	KD202075	7,5	10	10,0	35	100	40		
8,0	KD202080	8	12	12,0	40	125	55		
8,5	KD202085	8,5	12	12,0	45	125	55		
9,0	KD202090	9	12	12,0	45	125	55		
9,35	KD2020935	9,35	12	12,0	45	125	55		
9,5	KD202095	9,5	12	12,0	45	125	55		
10,0	KD202100	10	16	15,0	50	125	75		
10,2	KD202102	10,2	16	15,0	60	125	75		
10,5	KD202105	10,5	16	15,0	60	125	75		
11,0	KD202110	11	16	15,0	60	125	75		
11,2	KD202112	11,2	16	15,0	60	125	75		
11,5	KD202115	11,5	16	15,0	60	125	75		
12,0	KD202120	12	16	15,0	60	125	75		
14,0	KD202140	14	20	18,0	70	150	90		
15,5	KD202155	15,5	20	18,0	70	150	90		
16,0	KD202160	16	20	18,0	70	150	90		
17,5	KD202175	17,5	25	24,0	80	150	90		
20,0	KD202200	20	25	24,0	80	150	90		

Die Preise entnehmen Sie bitte unserer aktuellen Preisliste.
Please take prices out of our actual price list.

Bei der Bestellung bitte die Bestellnummer angeben: Best.Nr.: z.B. KD202102 und wenn gewünscht Beschichtung: z.B. TLX.
Please indicate order number: e.g. KD202045 and if wanted COATING: e.g. TLX.



Wir individualisieren für Sie.
Ihr **Anfrageblatt**.

Dieses Werkzeug fertigen wir genau für Ihre Anforderungen auf Anfrage!
Bitte füllen Sie das untere Blatt vollständig aus und faxen es an die

+49/ (0) 8234-9664-99

oder per Mail an

info@hufschmied.net und wir senden Ihnen gerne ein entsprechendes Angebot zu.

Ihr Hufschmied-Team

*We customize for you.
Your **request sheet**.*

*We also manufacture tools for your requirements on request.
Please fill in the correct parameters and send it by fax to*

+49/ (0) 8234 9664-99 or by mail

info@hufschmied.net

and we will gladly send you a quote.

Sincerely yours Hufschmied-Team

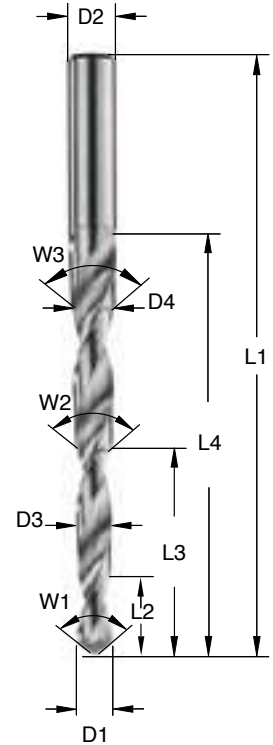

INDIVIDUALANFERTIGUNG · INDIVIDUAL PRODUCTION

Meine individuellen Daten
My individual data

zu bearbeitendes Material: Material to be processed:	<input type="text"/>
D1= <input type="text"/> mm ±	
D2= <input type="text"/> mm Tol.	
D3= <input type="text"/> mm ±	
D4= <input type="text"/> mm ±	
L1= <input type="text"/> mm ±	
L2= <input type="text"/> mm ±	
L3= <input type="text"/> mm ±	
L4= <input type="text"/> mm ±	
W1= <input type="text"/> °± (W1 = Spitzenwinkel)	
W2= <input type="text"/> °± (W2 + W3 = Senkerwinkel)	
W3= <input type="text"/> °±	
Schaftform / Shankform	HA <input type="radio"/> HB <input type="radio"/> HD <input type="radio"/> HE <input type="radio"/> Standard
Zähnezahl Z / Flutes F	<input type="text"/> 2 Standard
Ausspitzungsform / Headform	Form A <input type="radio"/> Form B <input type="radio"/> Form C <input type="radio"/> Form D <input type="radio"/> Form E <input type="radio"/>
Innenkühlung / Inner Coolant	ja <input type="radio"/> yes nein <input type="radio"/> no
Drallrichtung / Cutting Direction	rechtsdrall <input type="radio"/> gerade <input type="radio"/> linksdrall <input type="radio"/> right straight left

MEINE KONTAKTDATEN:
MY CONTACT:

Firma / Company

Name / Surname

Vorname / Name

Funktion / Function

Straße/Hausnr. / Road/House number

PLZ/Ort / Postcode/Location

Telefon / Phone

Telefax / Fax

E-Mail / E-mail

ANMERKUNGEN:
NOTES:

UNIVERSAL-LINE

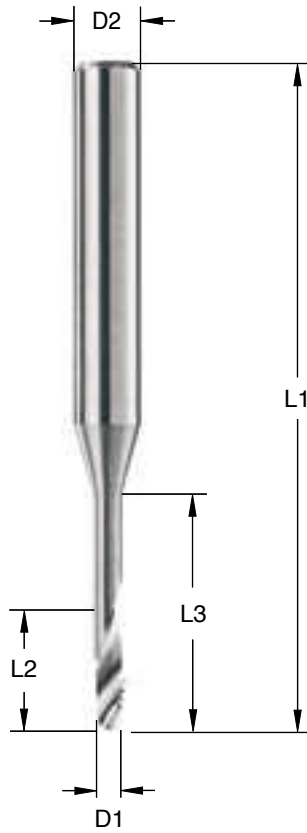
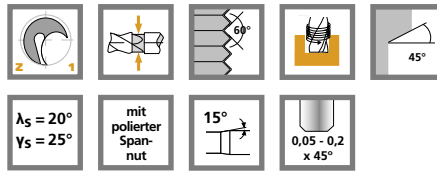

Durchmesserbereich:
M2 - M12
diameter range:
M2 - M12

Mögliche Beschichtungen:
ALX - Standard
DIP - auf Anfrage
possible coatings:
ALX - Standard
DIP - on demand

Andere Abmessungen, sowie Fein-,
Rund- und Panzergewinde auf
Anfrage.
Other thread versions and
dimensions on demand.

BESTELL-NUMMER ORDER NUMBER	M	D1 mm	D2 h6 mm	L2 +2 mm	L1 mm	L3 mm	E-Maß	P
110GF-M2	M 2	0,82	3	4	50	8	0,29	0,4
110GF-M2,5	M 2,5	1,1	3	6	50	10	0,32	0,45
110GF-M3	M 3	1,42	6	10	60	15	0,37	0,5
110GF-M4	M 4	1,74	6	15	75	20	0,52	0,7
110GF-M5	M 5	2,5	6	18	75	25	0,57	0,8
110GF-M6	M 6	3,0	8	20	75	30	0,75	1
110GF-M8	M 8	4,2	10	25	100	35	0,9	1,25
110GF-M10	M 10	5,39	12	30	100	40	1,1	1,5
110GF-M12	M 12	6,67	12	30	100	40	1,25	1,75